

User Manual

Eclipse Room Controller

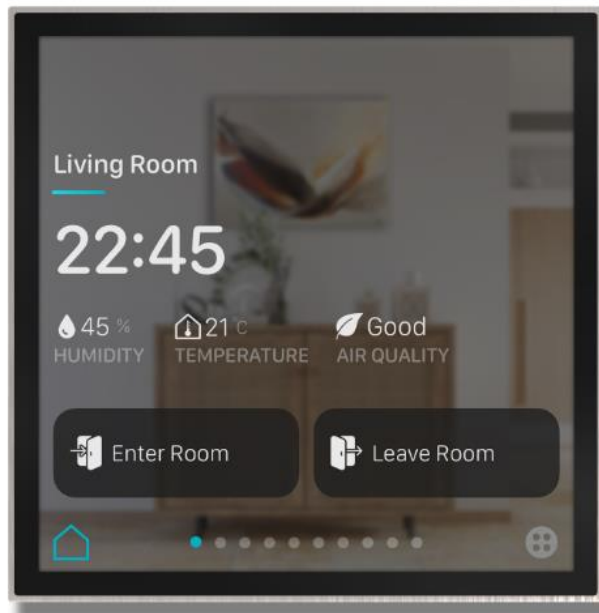

Document Version: 2.0

Last Revision: 18.09.2024

Product Code: CR-ECP-04-KNX

Table Of Contents

- 1. Presentation..... 3**
 - 1.1. Main Features 4
 - 1.2. Dimensions..... 5
- 2. Technical Specification..... 6**
 - 2.1. Installation 7
 - 2.1.1 Installation Site 7
 - 2.1.2. Mounting, Electrical Connection 7
- 3. ETS Parameters 9**
 - 3.1. General 9
 - 3.1.1. Proximity Sensor 10
 - 3.1.2. Brightness Sensor 10
 - 3.1.3. Humidity Sensor 11
 - 3.1.4. Co2 Sensor 12
 - 3.1.5. Time 13
 - 3.1.6. Scenes 13
 - 3.1.7. Temperature Sensor 15
 - 3.1.8. Display 16
 - 3.2. Function Page 17
 - 3.2.1. Page 1 – Main Page 20
 - 3.2.2. Page 1 – Navigation Page 22
 - 3.2.3. Page 1 – List View 23
 - 3.2.4. Page 1 – Detailed Control Element 24
 - 3.2.5. Page 1 – Status Display 48
- 4. Commissioning..... 49**

1. Presentation

Eclipse Room Controller is designed to be the most exclusive touch panel for rooms. Simply, one digital control panel equipped with multiple sensors to control all. The high-quality display and premium materials combined with a sleek and stylish design language that matches other Core products. At only 11mm in thickness, the Eclipse Room Controller is both discreet and elegant, blending seamlessly into any room decor.

Functionality

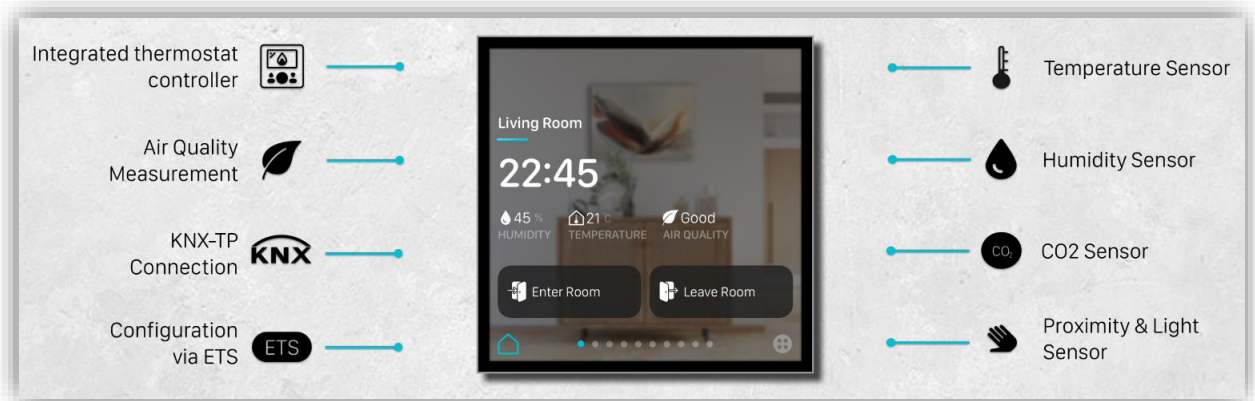

Material and Colour Options

Brushed Finish

Pure form of stainless steel, brass and aluminium are brushed with perfect craftsmanship to provide satin effect in each touch to the device.



Silky-Matte Finish

Aluminium is painted with unique colours and coated with special techniques to provide silky feeling in each touch to the product.



Ordering Tips:

Use online planner to create an Eclipse Room Controller.

<https://planner.core.com.tr/>

1.1. Main Features

INTUITIVE USER INTERFACE

The intuitive user interface of the Eclipse Room Controller is designed to provide a seamless control experience, making it easy to manage all your smart home devices with just a few taps. The large, easy-to-read icons and buttons, coupled with the device's intuitive navigation system, make it simple for anyone to use.

HIGH QUALITY DISPLAY

The crystal-clear HD display of the Eclipse Room Controller ensures that all information and graphics are displayed with incredible clarity and sharpness. This means that users can easily view all information and control their devices with ease, even from a distance. (4", 720 x 720 pixels)

EXTENSIVE APPLICATION

Eclipse Room Controller activates many functions. Switching, Dimming, RGB Control, Tunable White, Thermostat Functionality, AC Control, Blinds, Jalousie, Scene, Energy Display, Audio, Air Quality.

BUILT-IN THERMOSTAT

Eclipse Room Controller can control HVAC systems via built-in thermostat logic, temperature sensor and humidity sensor.

AIR QUALITY MEASUREMENT

Eclipse Room Controller measures CO2 inside the room with its built-in sensor. Air-quality of the room can be checked on main page or air-quality page in detail. Logic functions can be triggered according to the air-quality level via KNX.

ADAPTIVE BACKLIGHTS

Light sensor measures the ambient light in the room, allowing for automatic adjustment of the backlight brightness. With this advanced feature, the device can be customized to provide the perfect level of brightness for any environment.

PROXIMITY SENSOR

The Eclipse Room Controller is equipped with a sophisticated proximity sensor that detects when a user is approaching the device. In dark environments, the light of the display is automatically dimmed to provide a welcoming and comfortable user experience.

PAGE – ELEMENTS

Eclipse Room Controller has 12 pages with a maximum of 64 control elements. This extensive range of control options provides users with unparalleled control over their smart home devices.

1.2. Dimensions



Dimensional drawing (all dimensions are in mm)

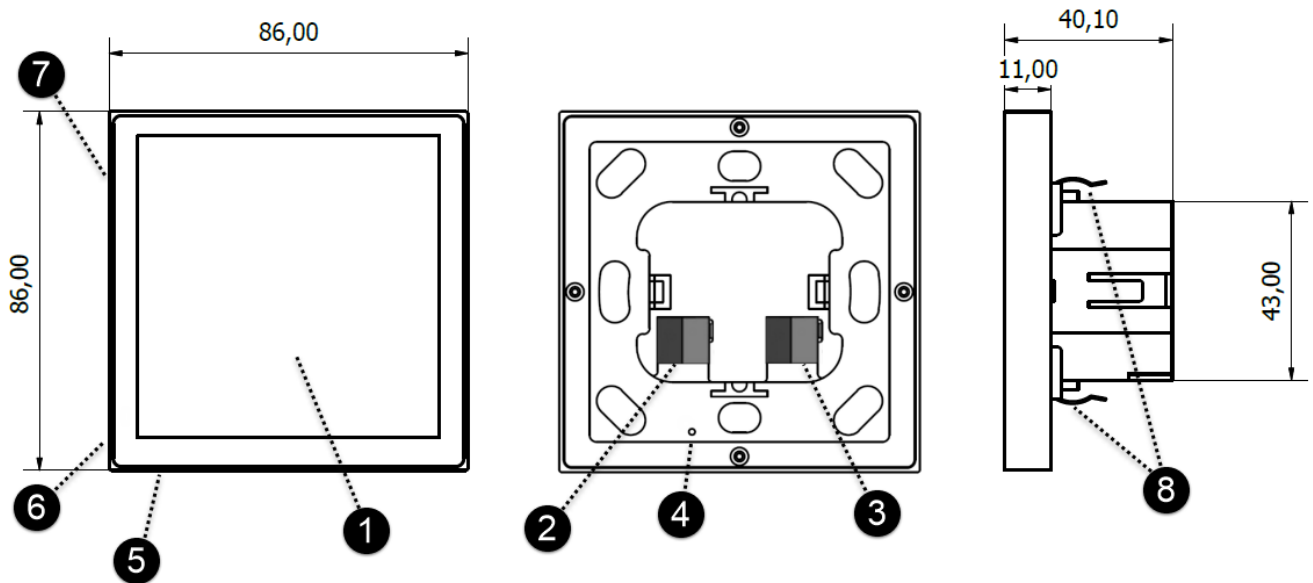

- | | |
|------------------------------|------------------------------------------------|
| 1. HD Display | 5. Position of Temperature and Humidity Sensor |
| 2. Power Connector (12V-30V) | 6. Position of CO2 Sensor |
| 3. KNX Connector | 7. SD Card Slot |
| 4. KNX Programming Button | 8. Mounting Clips |

2. Technical Specification

Processor:	Arm Cortex-A7 900MHz 512 MB DDR3 RAM Embedded Linux Operating System
Display:	IPS TFT 4" – 720px X 720px 400 cd/m ² HD Display
Sensors:	Temperature – Accuracy Rate: +/- 0,2°C Humidity – Accuracy Rate: +/- 2% CO ₂ Proximity & Light
Dimensions:	86mm X 86mm X 11mm
Casing Material:	Aluminium, Brass and Stainless Steel depending on the finish selection
Power:	12- 30 VDC - via KNX Auxiliary Power Supply or separate PS
Consumption:	< 70 mA from KNX Auxiliary Power Supply < 5 mA from KNX Bus-line
Connectivity:	KNX-TP
Programming Tool:	ETS
KNX Figures:	Max. Page: 12 Max. Control Element: 64
Installation:	German IEC/EN 60670 In wall Box

2.1. Installation

2.1.1 Installation Site

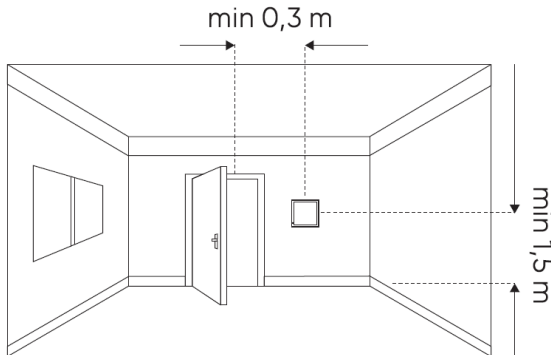

- The device should be positioned approximately 150 cm above the ground and 30 cm away from the door.
- The device should not be installed close to the heat source. The wall opposite the heat source will be appropriate for the installation.
- Contact with fluids to the device is to be avoided.

2.1.2. Mounting, Electrical Connection

1. Mount the metal mounting support.
(Included in the box.)

- ⚠ Use screws included in the box (M3x15 mm)
- ⚠ Do not overtighten the screw

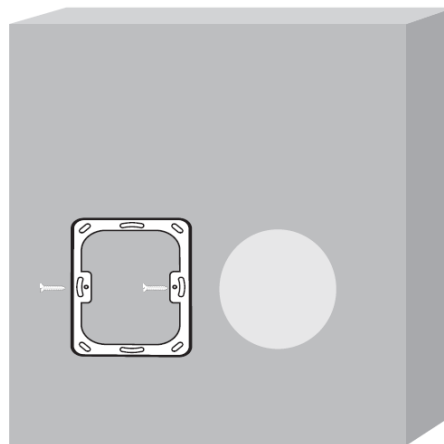

2. Connect power cable and KNX cable to the device. Check that polarity is correct.

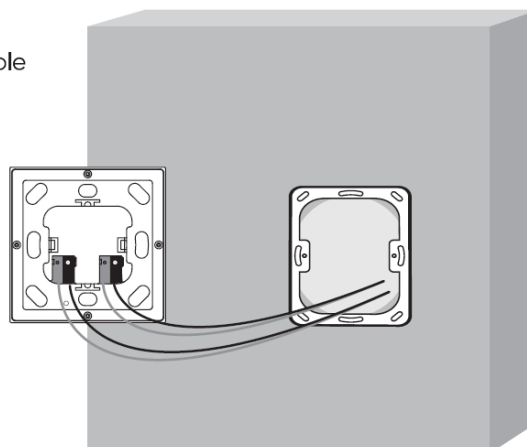

- 3. Place over the lower clips
- 4. Attach the top clips

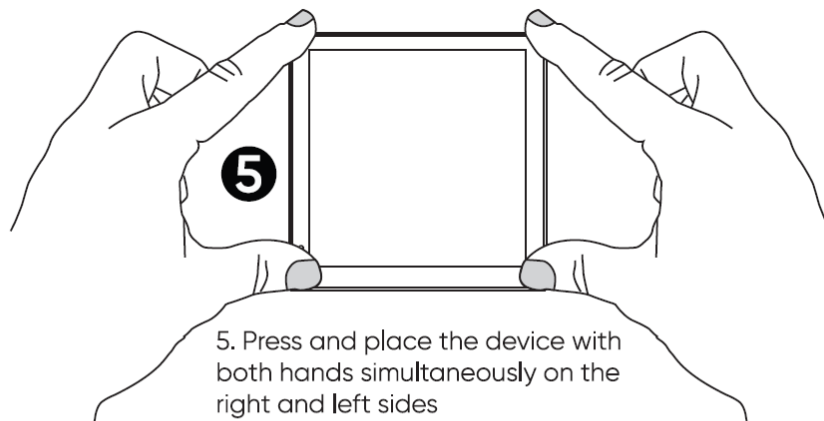
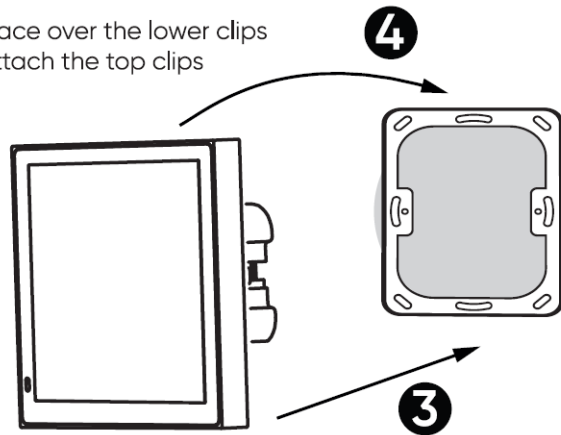

Pushing the device straight into the clips might damage

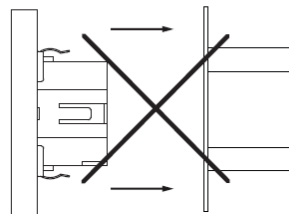

For installation video: https://www.youtube.com/watch?v=w7Oj0_RHpVY

3. ETS Parameters

Eclipse Room Controller must be configured and set up using the standard KNX configuration tool ETS. The ETS database for this device can be downloaded from ETS online catalogue.



For tutorial videos: https://www.youtube.com/playlist?list=PLtwbriT0bxi_0rqh9KTyEgKsq8VYcDyxP

3.1. General

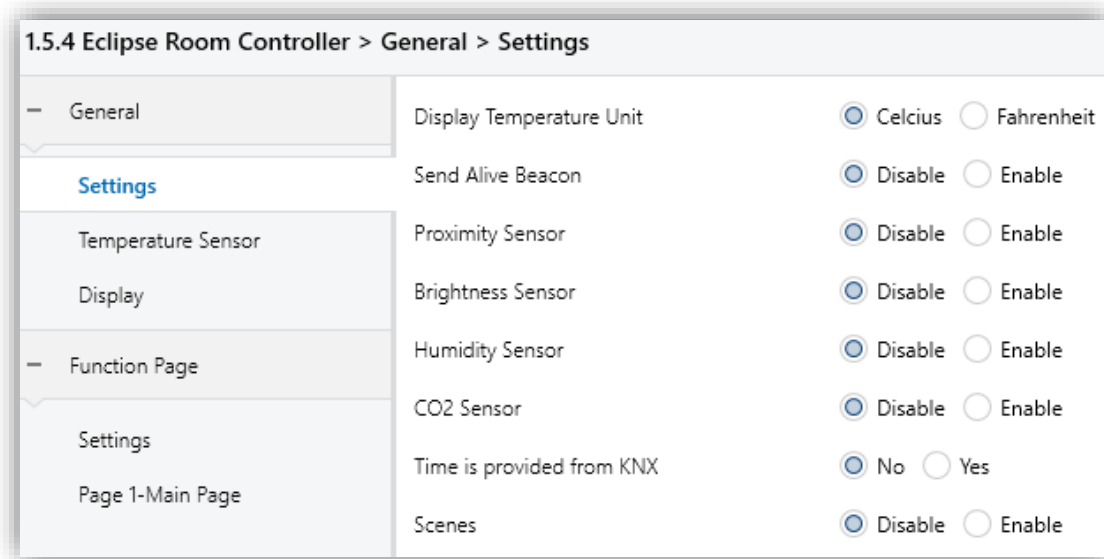

Display Temperature Unit: [Celsius, Fahrenheit]

Temperature unit can be selected for the device. Once selected, the device will use your preferred temperature unit for all temperature values displayed on the Room Controller.

Send Alive Beacon: [5...10...65535 s]

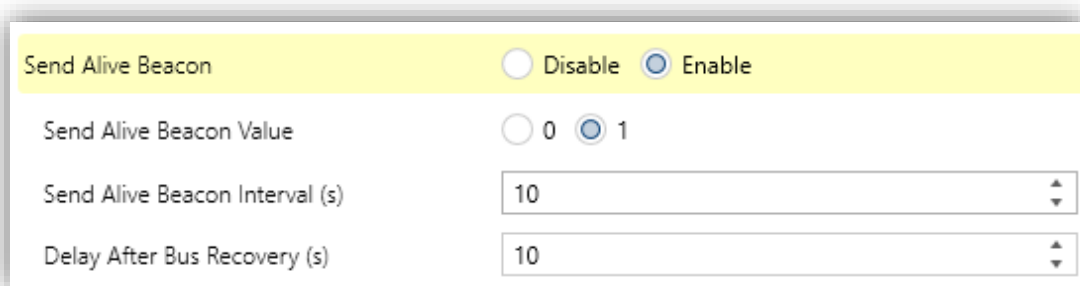

Parameter used to observe that the device and the application are running. It is disabled by default. When activated, Object Number 1 "Send Alive Beacon" will send selected value with defined time interval.

Delay After Bus Voltage Recovery: [5...10...65535 s]

The parameter defines the behaviour of the switch after bus power return. The delay time determines the period between bus voltage recovery and the point after which telegrams can be sent.

3.1.1. Proximity Sensor

Through the proximity sensor it is possible to reactivate the display automatically only when the user approaches the switch.

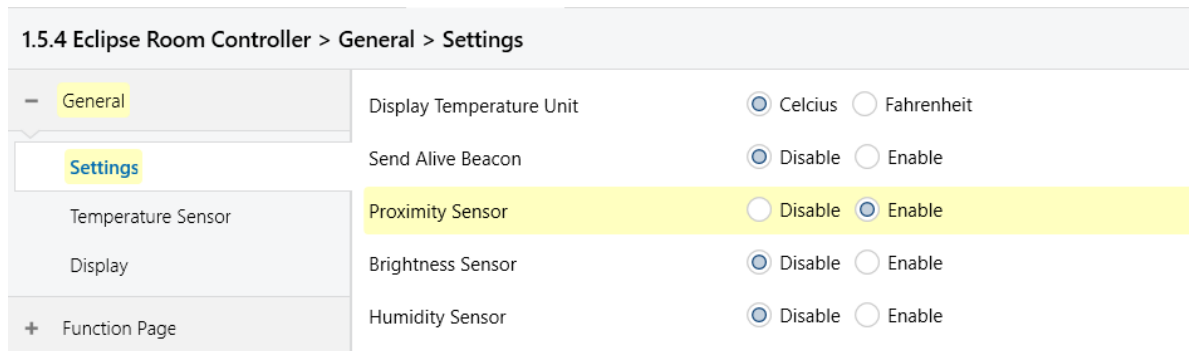

3.1.2. Brightness Sensor

Brightness Sensor [Disable, Enable]

Brightness sensor can be enabled to activate auto adjustment of display brightness according to ambient lux level which is measured by built-in light sensor.

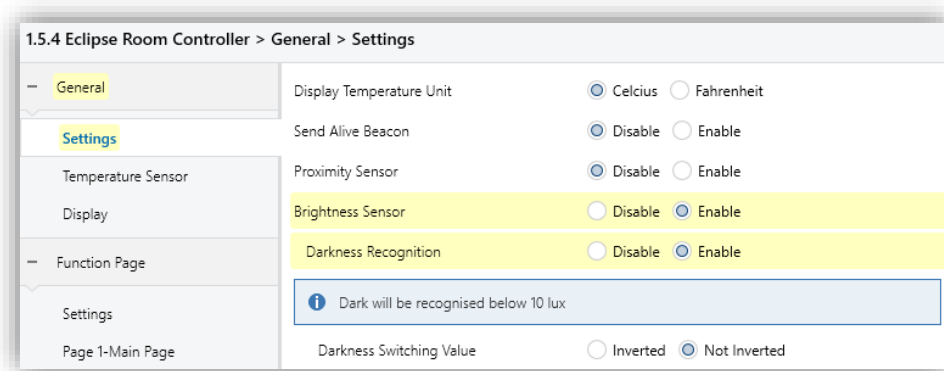

Darkness Recognition: [Disable, Enable]

Object “Darkness Switching Value – (0-Active)” can be activated by enabling “Darkness Recognition” parameter. If measured lux value is less than 10 lux, darkness will be recognised and transmitted via this object to KNX bus. Object value can be used inverse. [True, False]



3.1.3. Humidity Sensor

Humidity sensor tab contains following parameters.

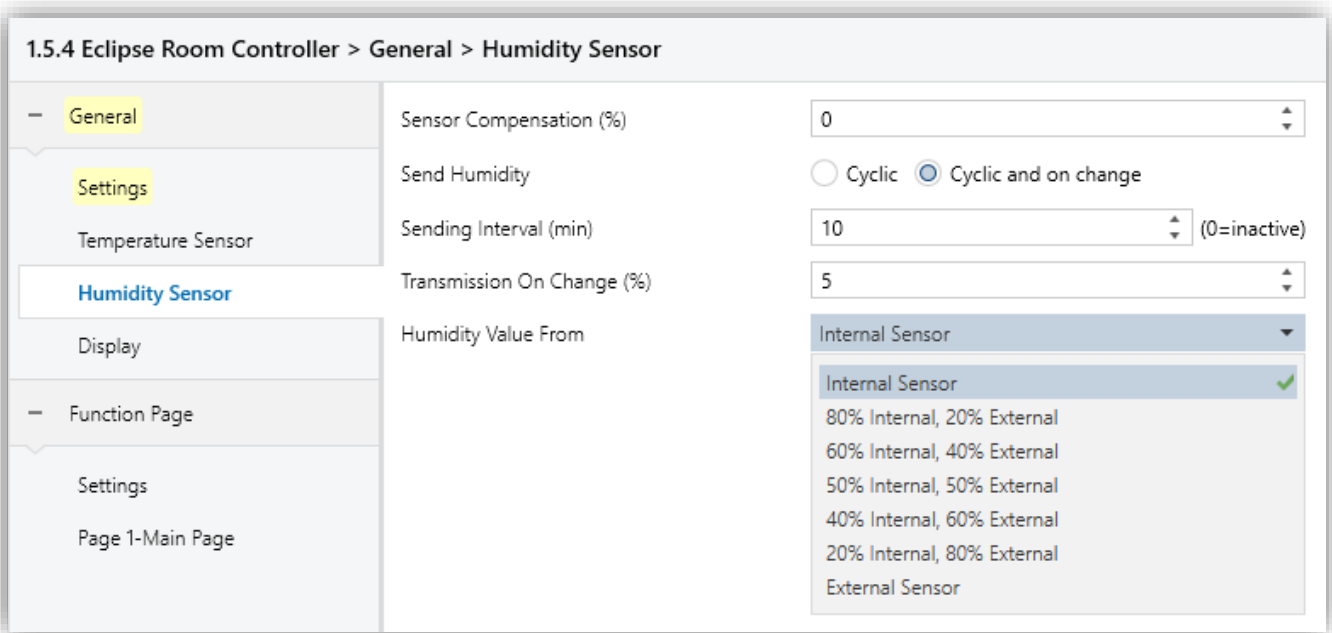

Sensor Compensation (%):

Measured humidity value can be shifted up or down by using sensor compensation value. [-5...0...+5]

Example: Assume that “3” is written to the sensor compensation box. Measured humidity percentage will be increased + 3%. If “-3” is written to the sensor compensation box. Measured humidity percentage will be decreased - 3%.

Send Humidity:

Object Number 3 “Humidity Value – Internal Value (%)” can be sent cyclically or by change of measured humidity.

Sending Interval (min) [0...10...255]

Transmission On Change (%) [1...5...255]

Humidity Value From:

Humidity value can be received by an external humidity sensor directly or partially according to selected percentage.

3.1.4. Co2 Sensor

CO₂ sensor tab contains following parameters.

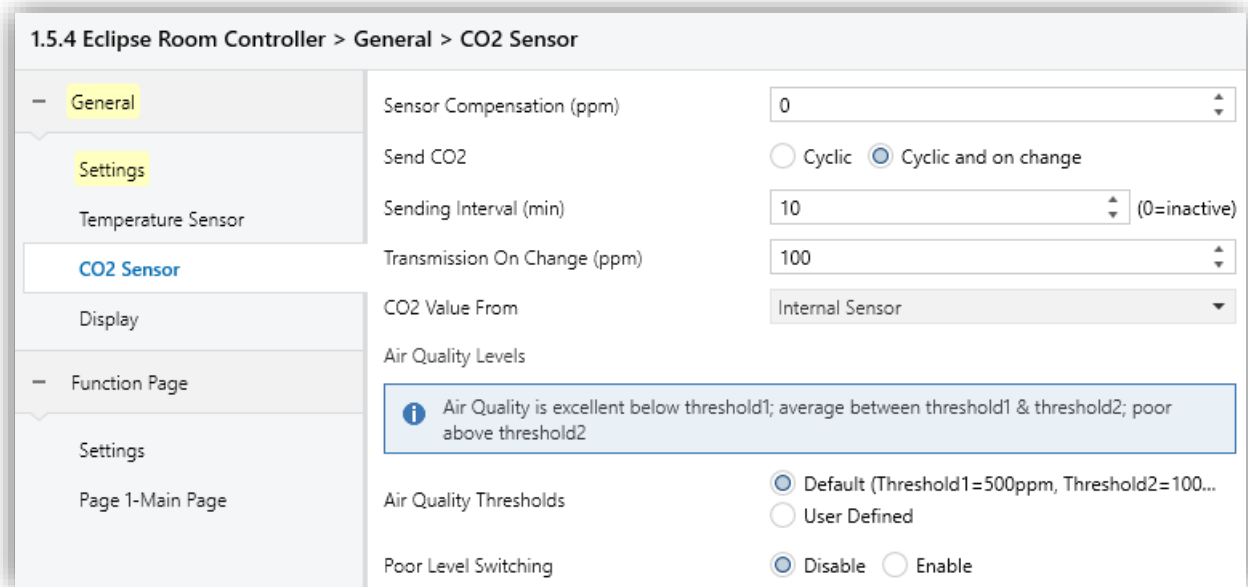

Sensor Compensation (ppm):

Measured CO₂ value can be shifted up or down by using sensor compensation value. [-500...**0**...+500]

Example: Assume that “100” is written to the sensor compensation box. Measured CO₂ ppm will be increased “100 ppm”. If “-100” is written, measured CO₂ ppm will be decreased “100 ppm”.

Send CO₂:

Object Number 5 “CO₂ Value - Internal Value (ppm)” can be sent cyclically or by change of measured ppm.

Sending interval time [0...**10**...255]

Transmission on change [10...**100**...500]

CO₂ value from:

CO₂ value can be received from an external CO₂ sensor directly or partially according to selected percentage.

Air Quality Thresholds:

Air quality is excellent below threshold 1, average between threshold 1 and threshold 2; poor above threshold 2. Threshold values can be defined by user.

Excellent ← **Threshold 1** → Average ← **Threshold 2** → Poor

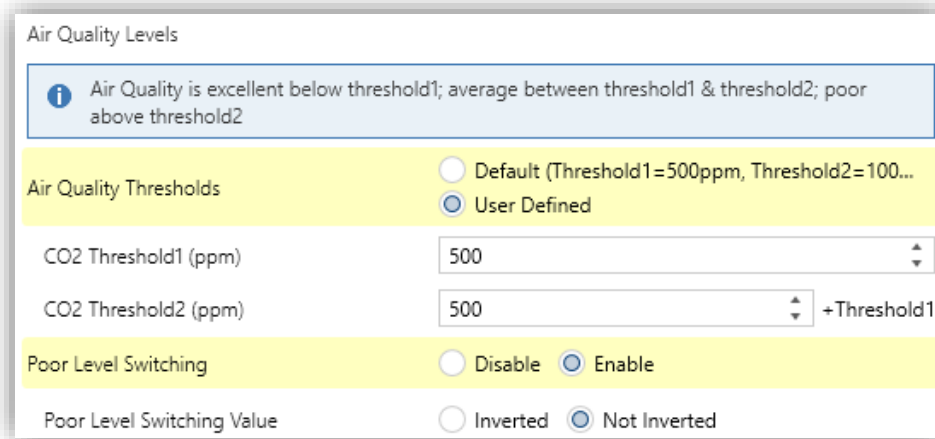

Poor Level Switching:

Object Number 7 “Poor Level Switching Value” can be activated. Object will send “Air Quality is Poor - Alarm” when air quality level is higher than “Threshold 2”. Object value can be inverted. [True, False]

3.1.5. Time

Time is provided from KNX:

If “yes” is selected, Object Number 10 “General - Time” will be activated to receive time information from KNX bus. Received time will be shown on the Main page of the device.

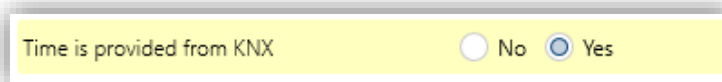

Otherwise, Room Controller uses built-in RTC (real time clock) for the clock on main page. Use KNX Group Monitor to adjust the time via writing “correct time” value to Object Number 10 “General - Time”.

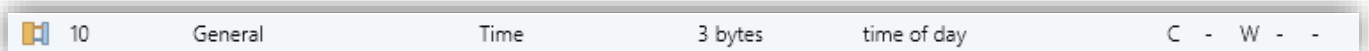

3.1.6. Scenes

Room Controller has 8 scene outputs (KNX objects) to send commands to KNX bus. Scene outputs are defined in 8 different scenes and can be used to send different values by recalling each scene separately.

Data type of each Scene Output can be selected as “1 Bit, 1 Byte Unsigned and 1 Byte Percentage”.

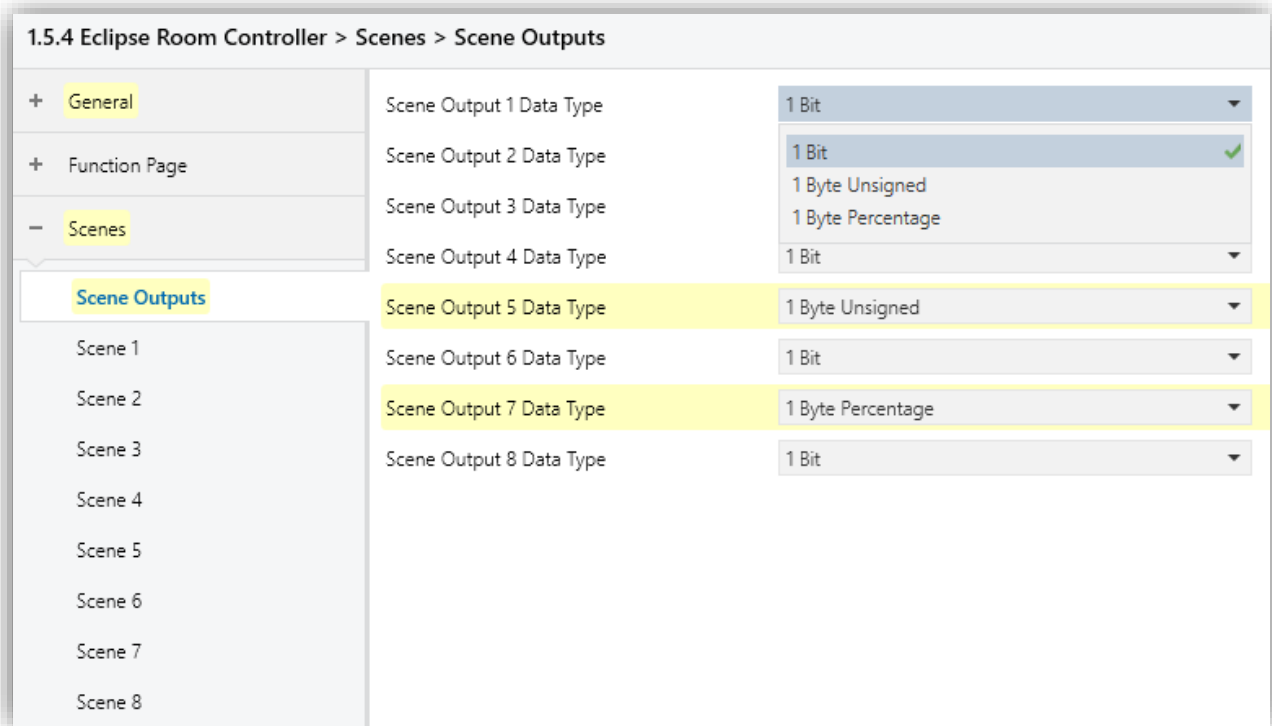

Scene number can be individually selected between 1 and 64 for each scene. Thus, scenes can be recalled by using "Scene number" via Object Number 613 "Scenes – Scene Recall".

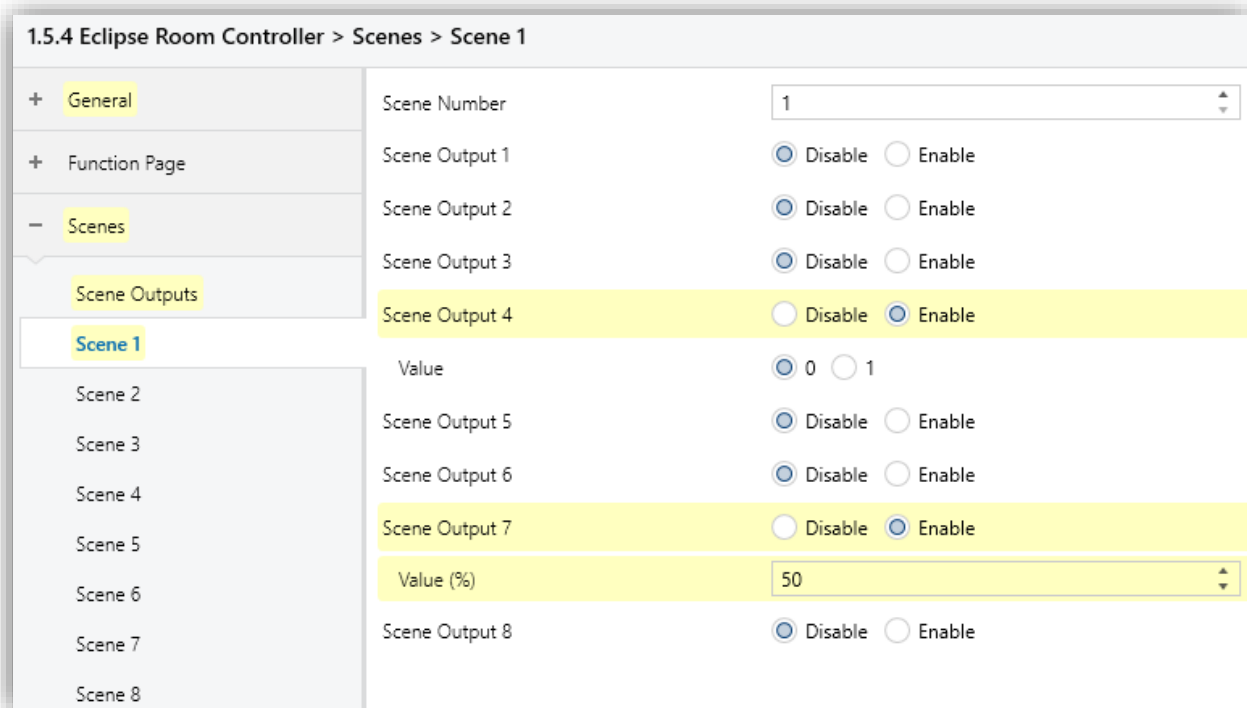

Any scene which is recalled by Object Number 613 will send value of enabled "Scene output" via Object Numbers 614-621 to KNX bus.

613	Scenes	Scene Recall	1 byte	scene number	C - W - U
614	Scenes	Scene Output 1 (1 Bit)	1 bit	switch	C - - T -
615	Scenes	Scene Output 2 (1 Bit)	1 bit	switch	C - - T -
616	Scenes	Scene Output 3 (1 Bit)	1 bit	switch	C - - T -
617	Scenes	Scene Output 4 (1 Bit)	1 bit	switch	C - - T -
618	Scenes	Scene Output 5 (1 Byte Unsigned)	1 byte	counter pulses (0..255)	C - - T -
619	Scenes	Scene Output 6 (1 Bit)	1 bit	switch	C - - T -
620	Scenes	Scene Output 7 (1 Byte Percentage)	1 byte	percentage (0..100%)	C - - T -
621	Scenes	Scene Output 8 (1 Bit)	1 bit	switch	C - - T -

3.1.7. Temperature Sensor

Temperature unit can be selected as Celsius or Fahrenheit.

Sensor Compensation (x0.1K):

Measured temperature value can be shifted up or down by using sensor calibration value. [-100...+100]

Example: Assume that "10" is written to the sensor compensation box. Calculation: $10 \times 0.1 = 1$ Celsius, measured temperature will be increased "+ 1 °C". If "-10" is written measured temperature will be decreased "-1 °C".

Send Temperature:

Object Number 8 "Actual Temperature – Internal Value" can be sent cyclically or by change of measured temperature.

Sending Interval (min) [0...**10**...255]

Transmission On Change (x0.1K) [1...3...100]

Temperature Value from:

Temperature value can be received from an external temperature sensor directly or partially according to selected percentage. Object Number 9 "External Temperature – External Value".

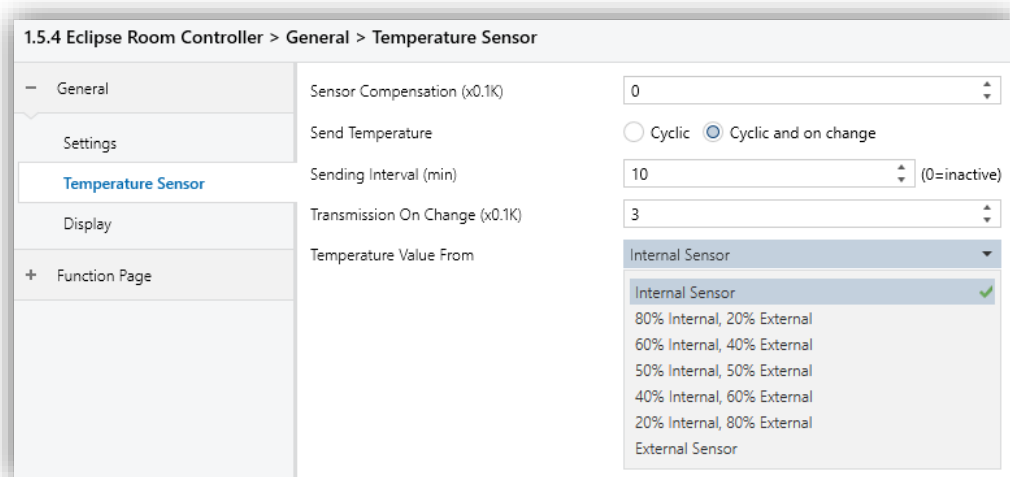

3.1.8. Display

Display parameter tab contains following parameters.

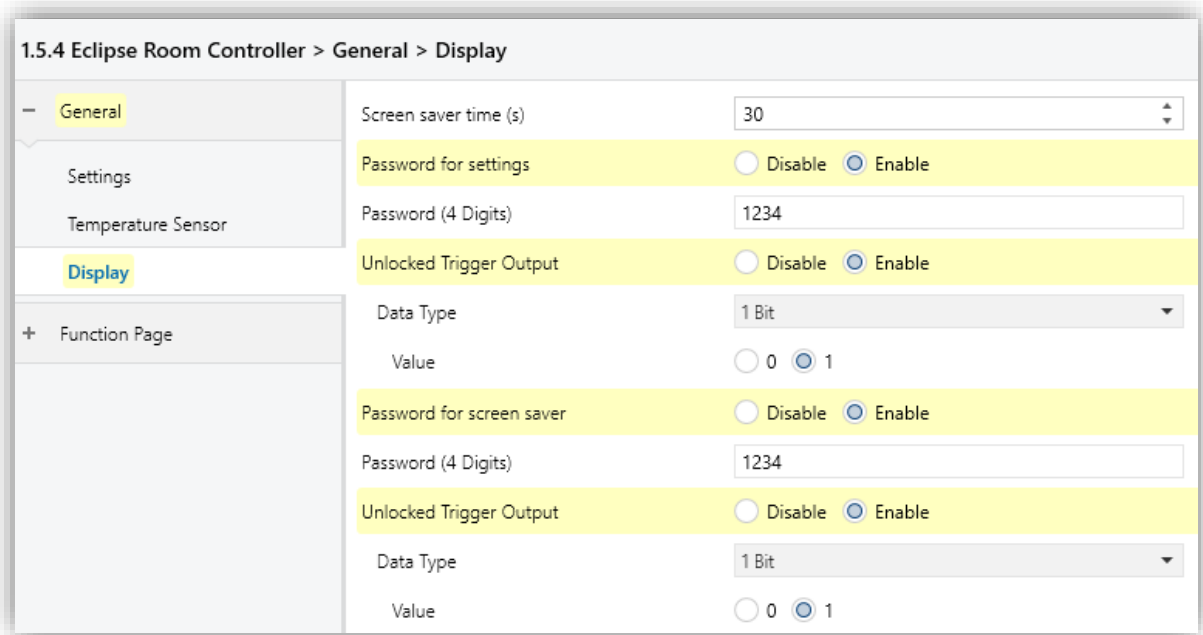

Screen saver time (s): [1 ... 30 ... 120]

Display goes into stand-by position when screen saver time is over.

Password for settings: (4 digits)

A "4 digit" password can be created to protect device settings. Settings can be changed only if correct password is entered.

Unlocked Trigger Output:

If settings page is unlocked by entering password then Object Number 11"Settings Password - Trigger" will send selected data to KNX bus.

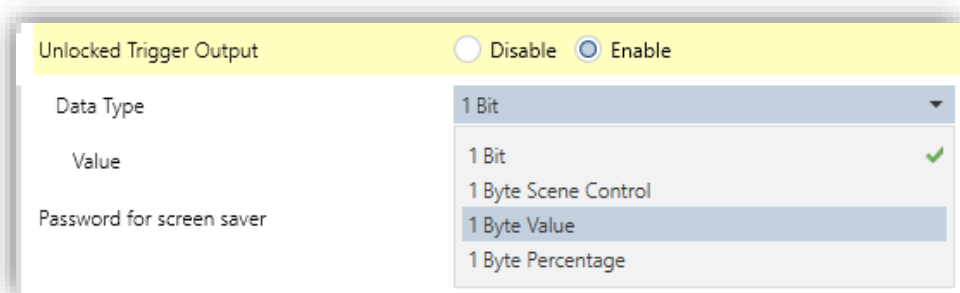

Password for screen saver: (4 digits)

A "4 digit" password can be created to protect the Room Controller. Screen can be activated only if correct password is entered.

Unlocked Trigger Output:

If screen saver is unlocked by entering password on the device then Object Number 12 "Screen Saver Password - Trigger" will send selected data to KNX bus.

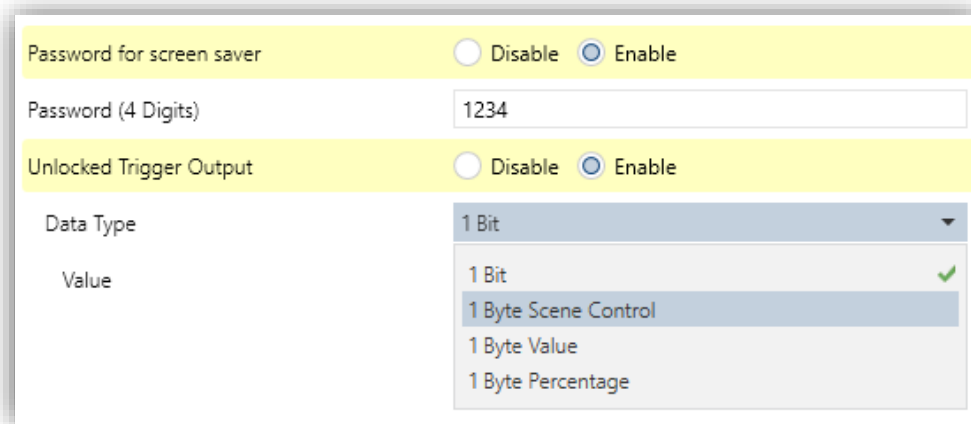

3.2. Function Page

Function pages can be enabled under "Function Page - Settings" parameter tab. Room Controller has a maximum of 12 identical function pages.

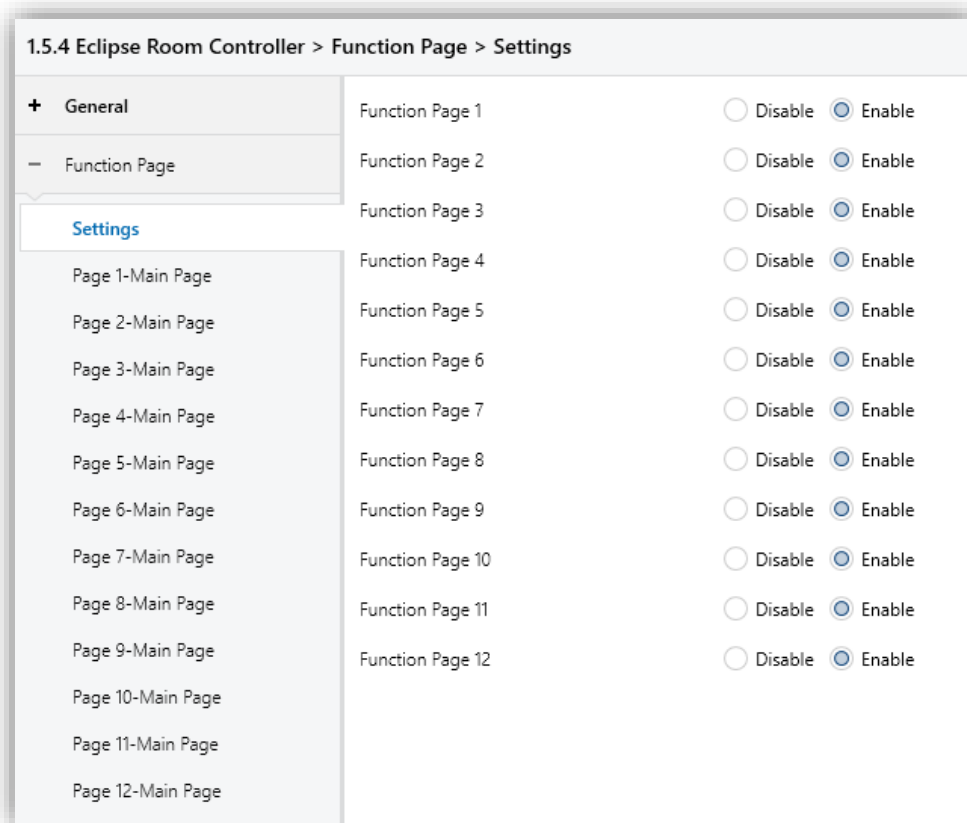

Each of function pages has following parameters.

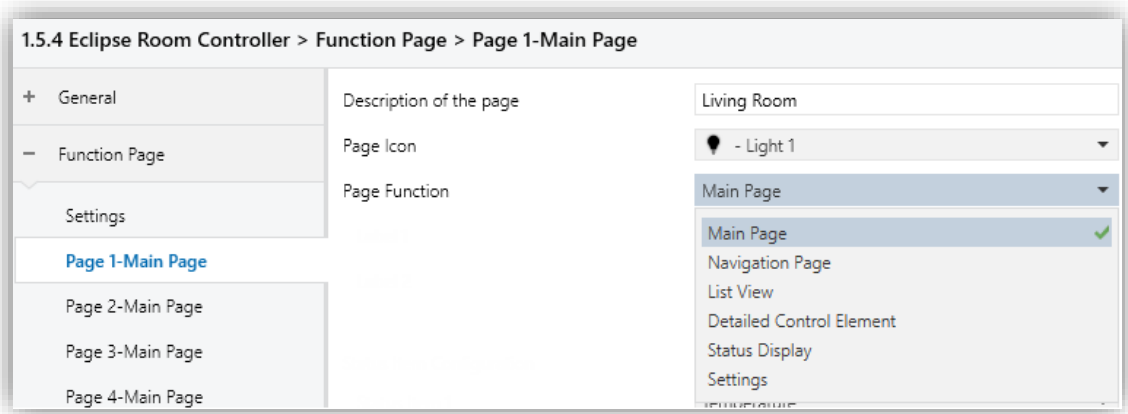

Description of the page: (16 characters allowed)

Description will be visible on left-top corner of the screen. Example: "Living Room".



Figure 1 – Description of the page

Page Icon:

A specific icon can be selected for the page from ready to use icon list. Selected icon will be visible on "Navigation Page" if page is added to navigation page. Figure 1 (Lights, Blinds etc.)

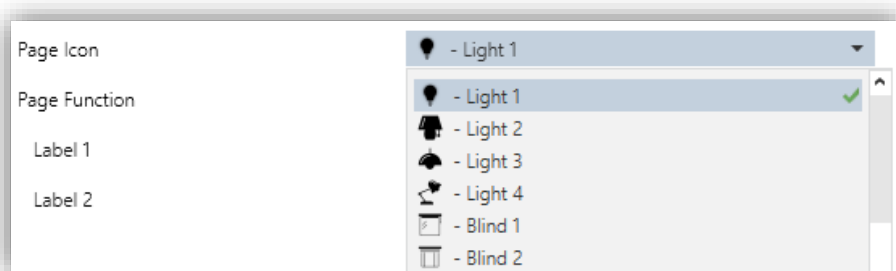

All available icons are listed below.

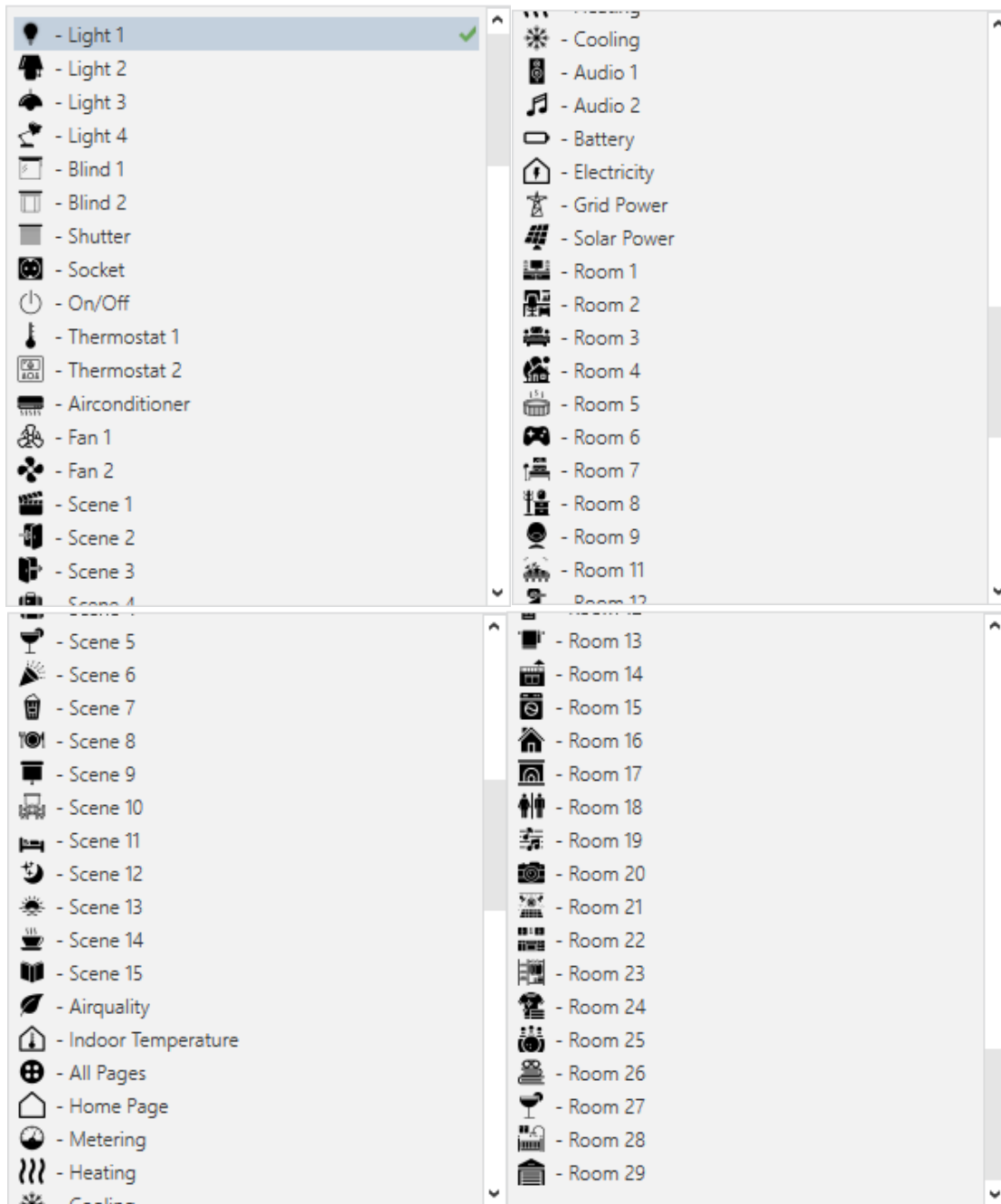

Page Function:

Following options are available for page function.

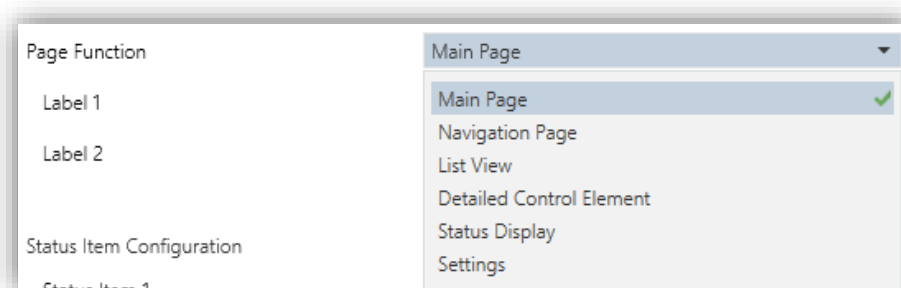

3.2.1. Page 1 – Main Page

Main Page contains “two of customized labels”, “clock”, “three of status items” and “two functional buttons”. Figure 2

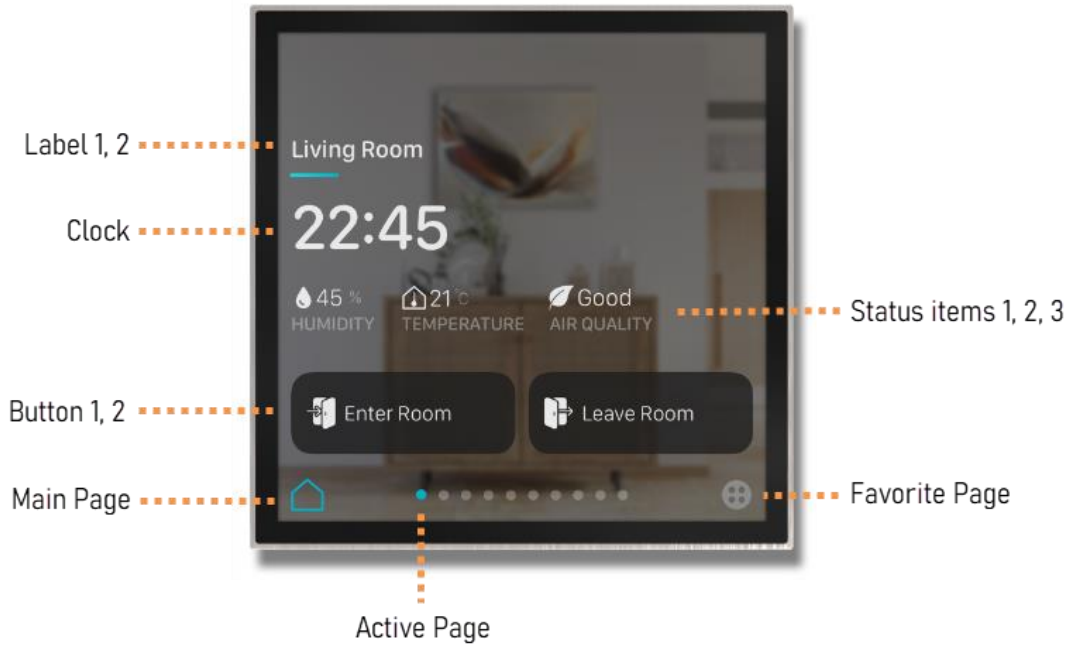

Figure 2 - Main Page view

1.5.4 Eclipse Room Controller > Function Page > Page 1-Main Page

General	Description of the page	Page 1
Function Page	Page Icon	- Light 1
Settings	Page Function	Main Page
Page 1-Main Page	Label 1	
	Label 2	
	Status Item Configuration	
	Status Item 1	None
	Status Item 2	None
	Status Item 3	None
	Button Configuration	
	Button 1 Function	None
	Button 2 Function	None

Parameter	Possible Values	Description
Label 1	User defined (16 characters max.)	Displayed on top-left of main page view.
Label 2	User defined (16 characters max.)	Displayed on top-left of main page view.
Status Item Configuration:		
Status item 1 Status item 2 Status item 3	Following options are selectable for each item. Temperature Humidity Air Quality CO2 VOC PM2.5 PM10 Brightness Wind speed	Status items are displayed on main page view with customized text and received or measured value of selected unit.
Status item 1, 2, 3 (Text)	User defined (16 characters max.)	Text is visible under measured value of selected unit. Check above Main page view on Figure 2.
Status item 1, 2, 3 (Sensor)	Internal, External	Value can be received from an external sensor using related object. Example: "Page 1- Main Page Status item 1 – Temperature".
Button Configuration:		
Button 1 Function Button 2 Function	Following datatypes are selectable for each button. 1 bit 1 Byte Scene Control 1 Byte Value 1 Byte Percentage	Two buttons can be used as "Scene button" on Main page view. Check above Main page view on Figure 2. (Enter Room, Leave Room)
1 bit 1 Byte Scene 1 Byte Value 1 Byte Percentage	[0, 1] [1...64] scene number [0...255] value [%0...%100] percentage	Selected data will be sent with button press.
Button 1 Function (Icon)	icon options (81)	Selected icon will be visible on the button.
Button 1 Function (Text)	User defined (16 characters max.)	Text will be visible on the button.

3.2.2. Page 1 – Navigation Page

Basically, “Navigation Page” contains shortcuts of other pages. 12 pages can be added to a navigation page at the same time. Each of pages is added with its own icon to “Navigation Page”. Figure 3

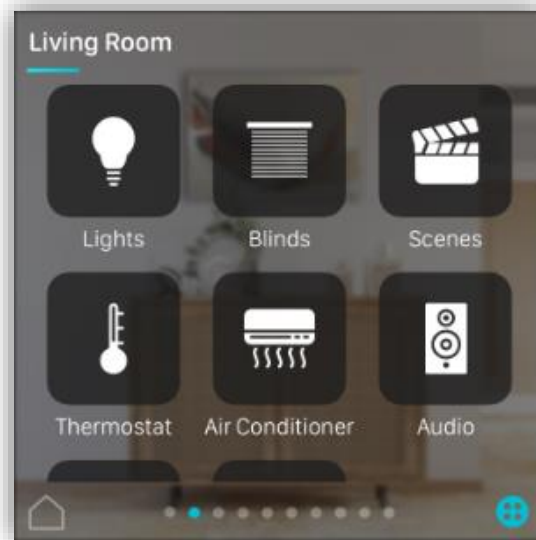
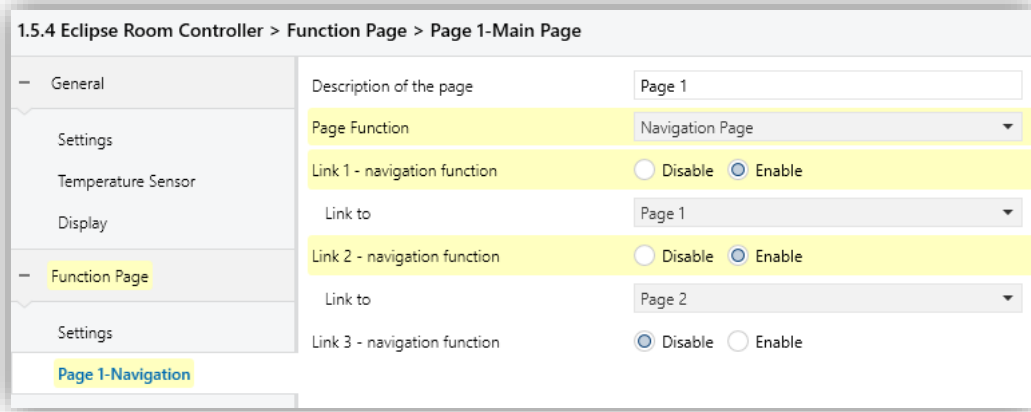

Figure 3 - Navigation Page

3.2.3. Page 1 – List View

Different type of control elements can be added to same page thanks to “List View”. Following control elements can be used. Figure 4, 5, 6

“Switch, Dimming, Shutter/Blind, Scene, Value, Tunable White Control”.

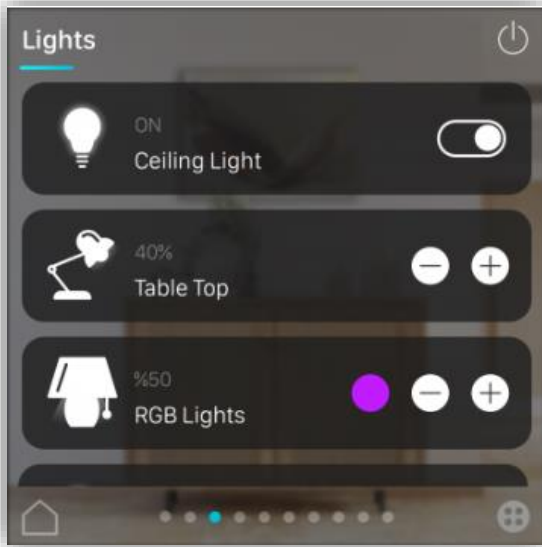

Figure 5 - List view (Lights)



Figure 4 - List view (Blinds)

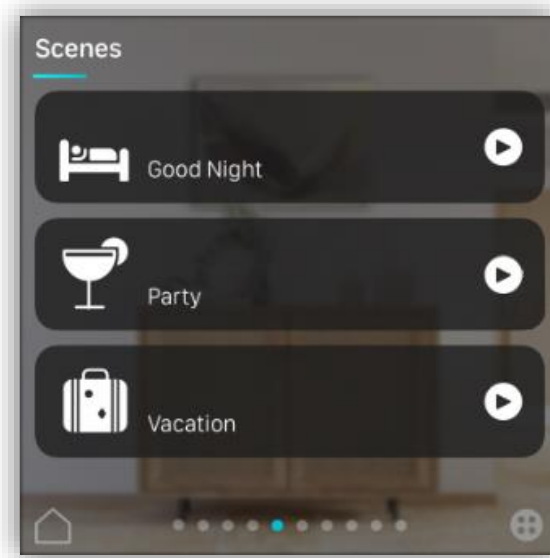
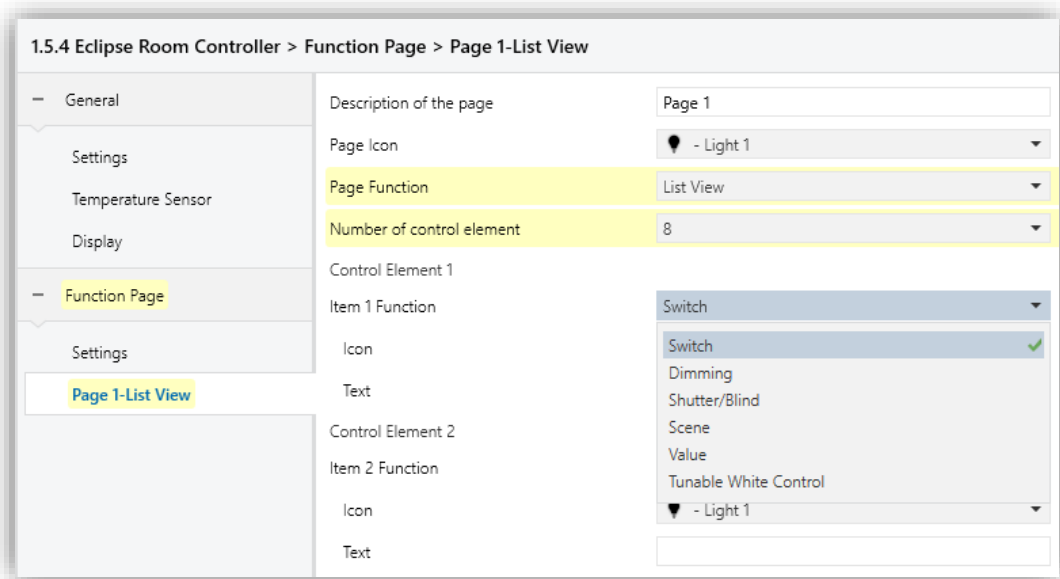

Figure 6 - List view (Scenes)



Parameter	Possible Values	Description
Control Element 1 (up to 8)		
Item 1 Function	Switch Dimming Shutter/Blind Scene Value Tunable White Control	Following functions are selectable for each control element.
Icon	icon options (81)	Selected icon will be visible on the control element. Figure 4, 5, 6
Text	User defined (16 characters max.)	Text will be visible on the control element. Figure 4, 5, 6
Item 1 Function (Shutter Blind) Blind position	Disable, Enable	Enables status object for blind position.
Item 1 Function (Shutter Blind) Slat position	Disable, Enable	Enables status object for Slat position.
Item 1 Function (Scene) Scene Number	1..64	Selected scene number is used to recall.
Item 1 Function (Scene) Mode	1. Send scene 2. Send scene and save at long press	If option 2 is selected, current position of lighting, blinds etc. can be saved on the actuator.
Item 1 Function (Tunable White Control) Color Temperature Min.	1000...10000	Defines the minimum color temperature that can be selected on control element.
Item 1 Function (Tunable White Control) Color Temperature Max.	1000...10000	Defines the maximum color temperature that can be selected on control element.

3.2.4. Page 1 – Detailed Control Element

"Detailed Control Element" can be used to focus only one control type in detail with all available functions. Figure 7, 8, 9, 10

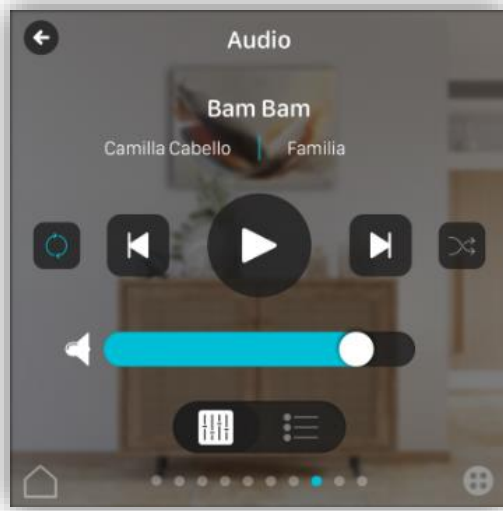

Figure 7 - Audio Control



Figure 8 - RGB Color wheel

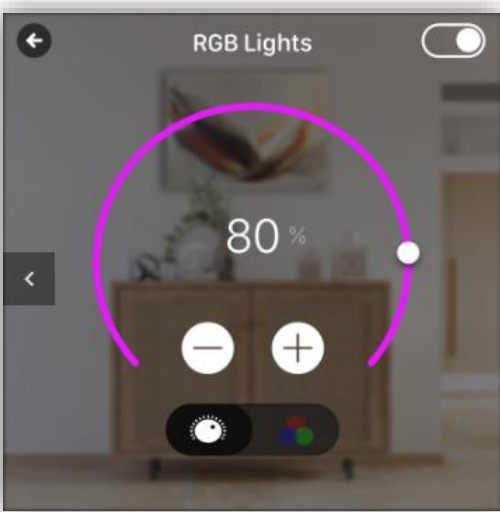

Figure 7 - RGB Brightness Level

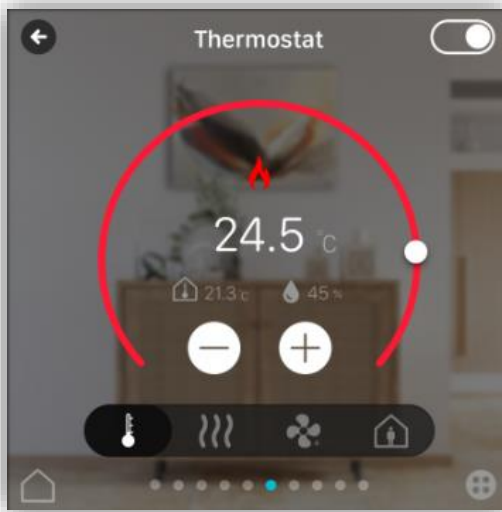

Figure 10 - Thermostat

Parameter	Possible Values	Description
Detailed Control Element		
Page Function	Switch Dimming Shutter/Blind Scene Value Tunable White Control RGBW Control General Thermostat(RTC) Slave Thermostat Air Conditioner Control Audio Control	Following functions are selectable for each detailed control element.
Shutter Blind		
Blind position	Disable, Enable	Enables status object for blind position.
Slat position	Disable, Enable	Enables status object for Slat position.
Scene		
Scene Number	1..64	Sets scene number will be recalled via scene object.
Mode	1. Send scene 2. Send scene and save at long press	If option 2 is selected, current position of lighting, blinds etc. can be saved on the actuator.
Tunable White Control		
Color Temperature Min.	1000... 2000 ...10000	Defines the minimum colour temperature that can be selected on control element.
Color Temperature Min.	1000... 6000 ...10000	Defines the maximum colour temperature that can be selected on control element.
RGBW Control		
Control Type	RGB, RGBW	Sets the control type according to lighting source.
Data Type	1x3 Byte 3x1 Byte	Sets the data type to control RGB lighting.
General Thermostat (RTC)		
Activates parameter tabs for RTC under Page 1.		
Settings		
Control Mode	Heating Cooling Heating and Cooling	Control mode of thermostat can be selected for Heating, Cooling, and Heating and Cooling together.
Heating and Cooling Control Value Output	Via 1 object Via 2 objects	Output value for Heating and Cooling can be sent via same object or 2 separate objects. In this way, heating and cooling control value commands can be sent separately.

Behavior of Control Mode at Bus Recovery	As before voltage failure Heating Cooling	The parameter defines the behavior of the control mode after bus power return.
Switchover of Control Mode	Only via Object Local and via object Automatic	Parameter makes possible to switch between the heating and cooling mode of the device.

3.2.4.1 General Thermostat (RTC)

3.2.4.1.1. Settings

Control Modes: Heating, Cooling, Heating and Cooling]

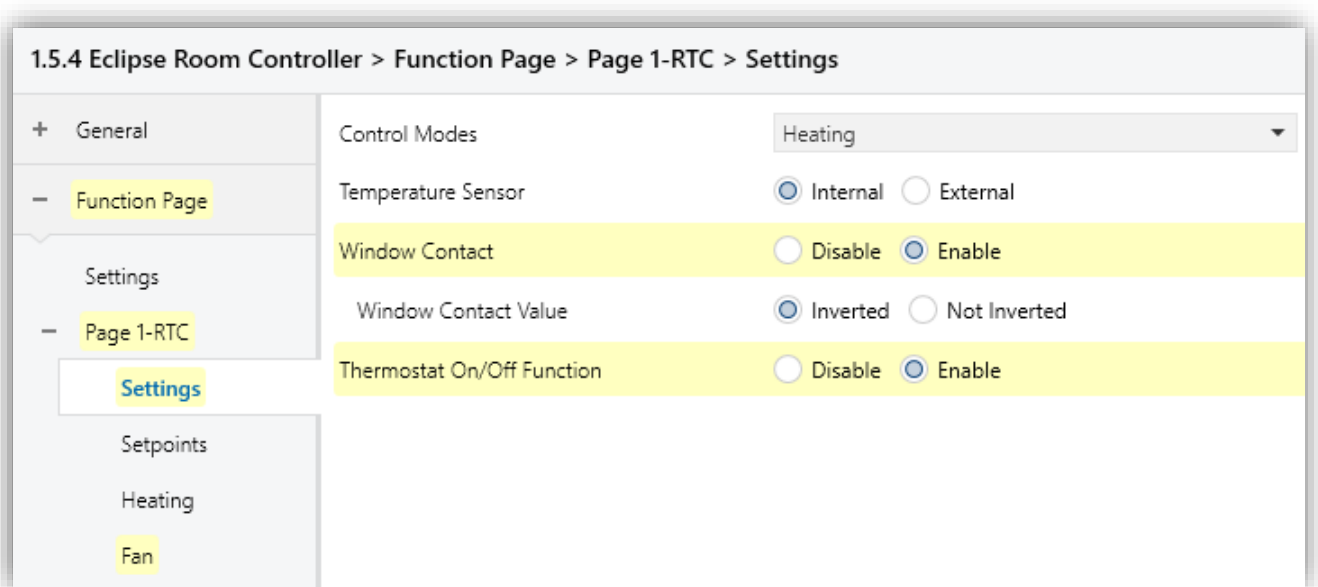

Temperature Sensor:

Temperature value can be received from an external temperature sensor directly or internal sensor can be used as default.

Window Contact:

Window Contact (1-Open) object can be used to take thermostat control in stand-by position according to window status. If window is open thermostat will stop working.

Thermostat ON/OFF Function:

Thermostat ON/OFF Function is used to turn the thermostat ON and OFF. Switch object and status object will be created after enabling this parameter.

3.2.4.1.2. Setpoints

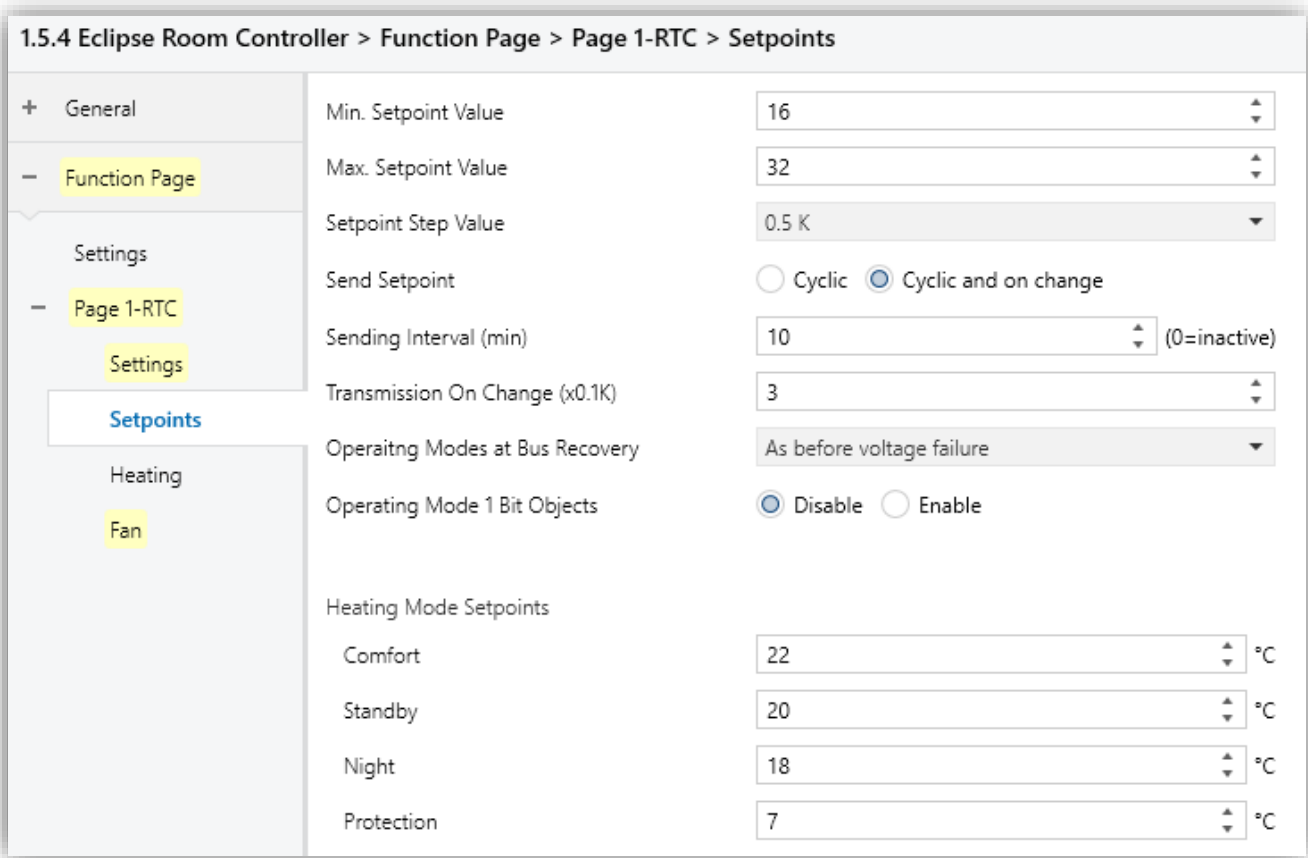

Min. Setpoint Value: [5...16...40]

Defines the minimum temperature setpoint value for the thermostat function. Any temperature value lower than Min. Setpoint Value cannot be written or selected on setpoint temperature objects.

Max. Setpoint Value: [5...32...40]

Defines the maximum temperature setpoint value for the thermostat function. Any temperature value higher than Max. Setpoint Value cannot be written or selected on temperature objects.

Setpoint Step Value: [0.1...0.5...1]

Increase/Decrease value of current setpoint by pressing +/- button on the page of Detailed Control Element.

Send Setpoint (°C): [Cyclic...Cyclic on change]

Current setpoint can be sent cyclically or by change of measured temperature via status Setpoint object.

Sending interval (min): [0...10...255] 0=Inactive

Defines the time period of sending setpoint value via "Status Setpoint" object.

Transmission on change (x0.1 K): [1...3...100]

Defines the minimum temperature change to send setpoint value via "Status Setpoint" object.

Operating Mode at Bus Recovery:

The parameter defines the behavior of the thermostat after bus power return. Operating mode can be changed to following options after a power return:

- As before voltage failure
- Comfort
- Standby
- Night
- Protection

Each operating mode has a different temperature setpoint.

Operating Mode 1 Bit Objects:

Parameter determines the data type of operating mode objects. Data type of operating mode objects can be used as “1 bit” with separate objects for each operating mode if this parameter is enabled. Status Objects will send current status of operating mode after change.

28	Page 1-General Thermostat (RTC)	Comfort Mode	1 bit	state	C - W - -
29	Page 1-General Thermostat (RTC)	Status Comfort Mode	1 bit	state	C R - T -
30	Page 1-General Thermostat (RTC)	Standby Mode	1 bit	state	C - W - -
31	Page 1-General Thermostat (RTC)	Status Standby Mode	1 bit	state	C R - T -
32	Page 1-General Thermostat (RTC)	Economy/Night Mode	1 bit	state	C - W - -
33	Page 1-General Thermostat (RTC)	Status Economy/Night Mode	1 bit	state	C R - T -
34	Page 1-General Thermostat (RTC)	Building Protection Mode	1 bit	state	C - W - -
35	Page 1-General Thermostat (RTC)	Status Building Protection Mode	1 bit	state	C R - T -

As default,

1 Byte Object [DPT_HVACMode];

Object “Page 1 General Thermostat (RTC) – Operating Mode” can be used to change between different modes. Object “Status Operating Mode” will send current status of operating mode after change.

- \$01 – Comfort [20.102 DPT_HVAC]
- \$02 – Standby [20.102 DPT_HVAC]
- \$03 – Economy [20.102 DPT_HVAC]
- \$04 – Protection [20.102 DPT_HVAC]

26	Page 1-General Thermostat (RTC)	Operating Mode	1 byte	HVAC mode	C - W - -
27	Page 1-General Thermostat (RTC)	Status Operating Mode	1 byte	HVAC mode	C R - T -

Heating Mode Setpoints:

General Thermostat (RTC) has “4” operating modes; “Comfort Mode, Standby Mode, Night Mode and Protection Mode”. Each operating mode has their own predefined setpoint temperature.

Changeover of operating modes can be achieved through “Operating Mode” communication objects.

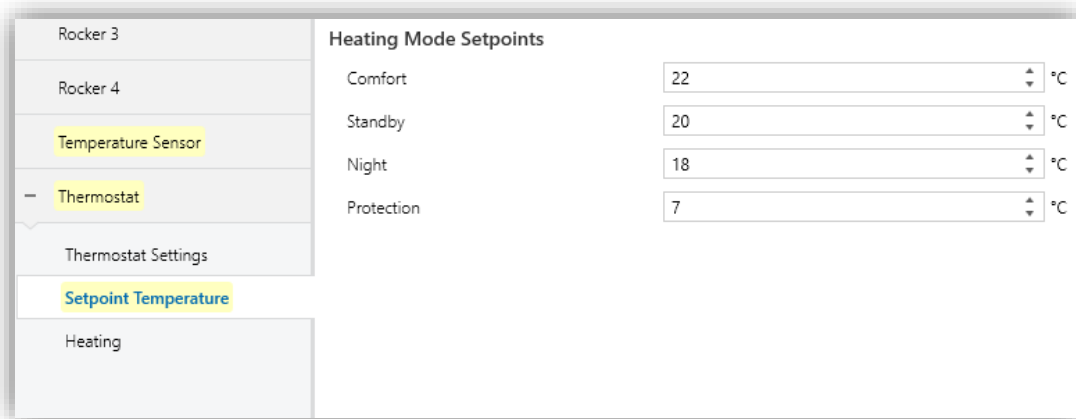

3.2.4.1.3. Heating - Control Type: [2-Point Control ON/OFF]

Control Type: [2-Point Control (On/Off), Switching PI Control (PWM), Continuous PI Control]

Operates as a simple switch around the setpoint temperature using hysteresis values. “Hysteresis” prevents the output value from oscillation and give larger margin to turning heat or cool on and off. If system is more an active system, hysteresis values should be given larger and more inactive values.

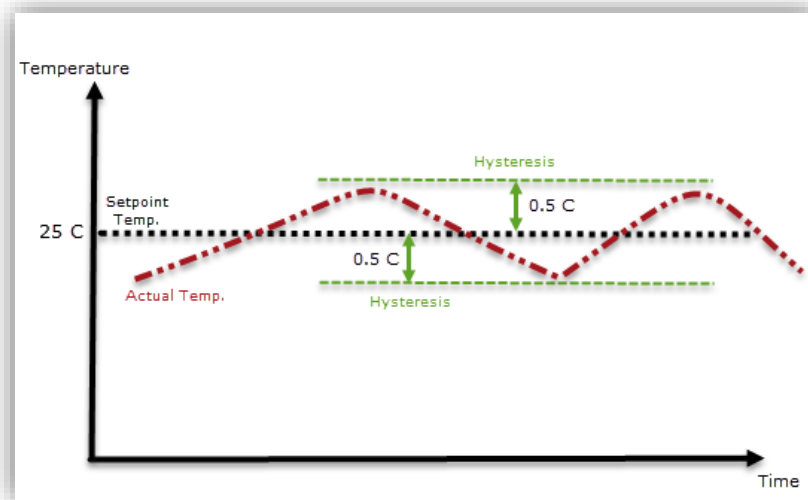

Sending Interval (min): [0...15...255] 0=inactive

Determines cyclic sending period of Object “General Thermostat - Heating 2 Point Control Value”.

Hysteresis +/- (x 0.1 °C): [1...5...255]

Determines Hysteresis value to control “Heating 2 Point Control Value” output more accurate. “Hysteresis” prevents the output value from oscillation and give larger margin to turning heat or cool ON and OFF. If system is more an active system, hysteresis values should be given larger and more inactive values.

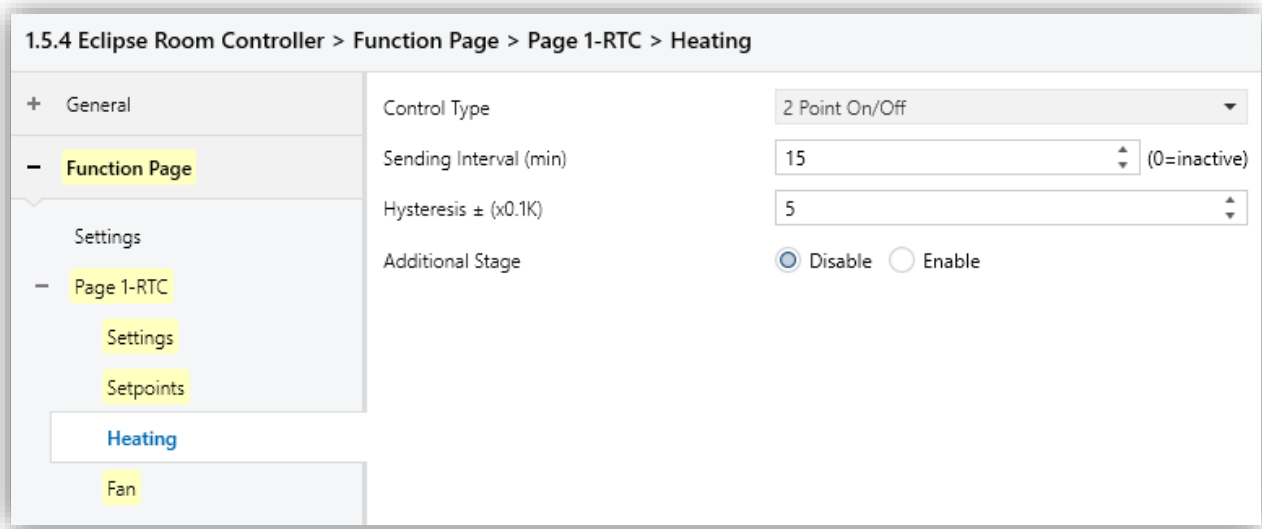

Additional Stage: Explained in [#3.2.4.1.6. Heating - Additional Stage](#)

3.2.4.1.4. Heating - Control Type: [Switching PI Control PWM]

PI algorithm is used to calculate control signal. After calculation, control signal is converted into a pulse-interval signal. This means PWM cycle is divided into “1 bit ON/OFF” output commands based on control value. PWM period and type of heating should be selected according to the used room and type of heating.

PWM Period Time (min): [1...10...255]

Defines PWM period time. If control value is calculated %50. Then control value will be ON for 5 minutes and OFF for second 5 minutes. Please check following graphic.

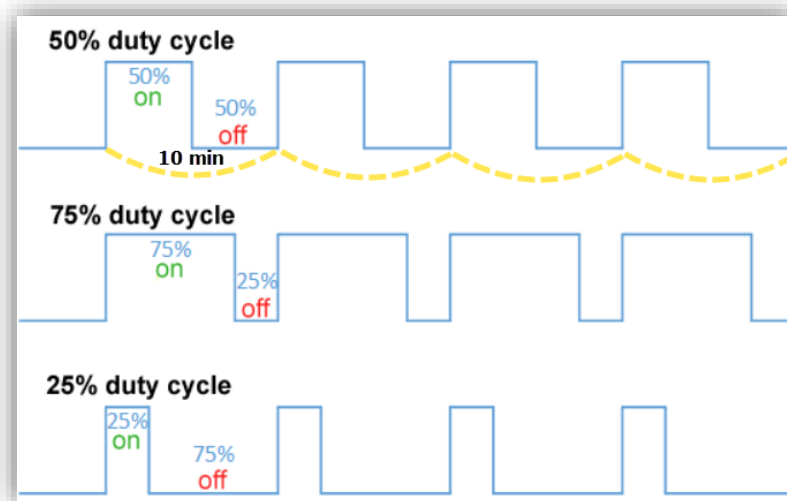

Heating Type: Multiple heating types with preset parameters are available to the user.

- Floor Heating (5K/240)
- How Water Heating (5K/150)
- Electrical Heating (4K/100)
- Fan coil (4K/90)
- User Defined

If the required heating type is not available, individual parameters can be specified in the "User Defined" configuration.

Proportional Range (x0.1 °C): [10...50...100]

Defines the proportional range of control. Parameter changes the control speed of the controller.

Integration Time (min): [1...240...255]

Defines the reset time of controller. Integration Time has the effect of moving the room temperature slowly toward, and ultimately reaching the setpoint value. Depending on the type of system used, parameter needs to have different values. In general, the more inactive the overall system, the greater time is needed.

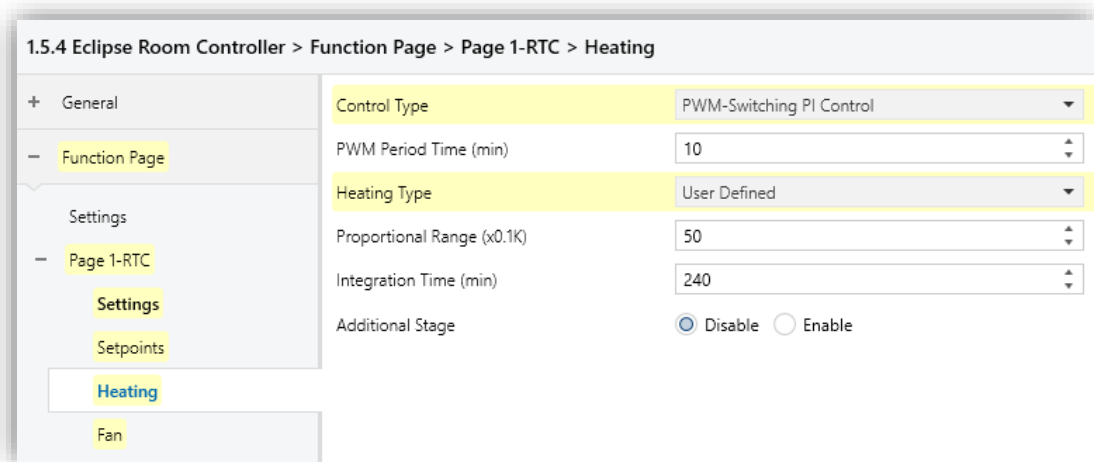

Additional Stage: Explained in [#3.2.4.1.6. Heating - Additional Stage](#)

3.2.4.1.5. Heating - Control Type: [Continuous PI Control PWM]

PI algorithm is used to calculate control signal and adjusts its output value between 0% and 100% to match the difference between the actual temperature and the setpoint temperature and enables an accurate regulation of the room temperature to the setpoint value. PI values should be selected compatible with the room and the type of heating system that needs to be controlled. Default PI values are defined for most common heating types. User defined values can be used for different rooms and different heating types for better performance. Using default values as a reference point and adjusting these values according to system might increase controller performance.

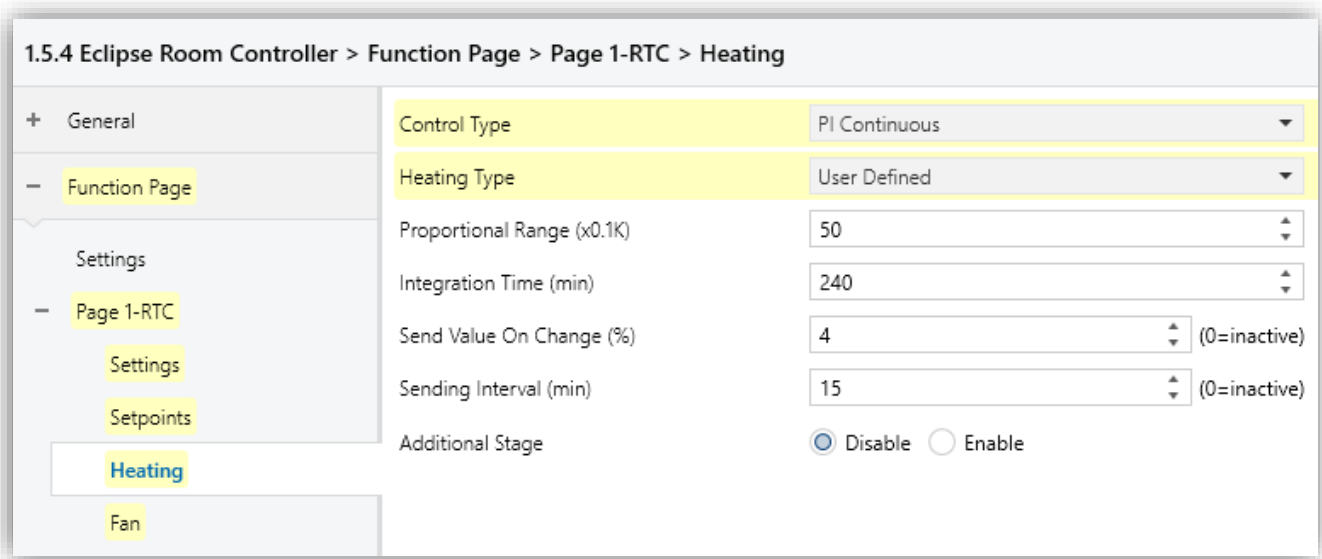

Heating Type: Multiple heating types with preset parameters are available to the user.

- Floor Heating (5K/240)
- How Water Heating (5K/150)
- Electrical Heating (4K/100)
- Fan coil (4K/90)
- User Defined

If the required heating type is not available, individual parameters can be specified in the “User Defined” configuration.

Proportional Range (x0.1 °C): [10...50...100]

Defines the proportional range of control. Parameter changes the control speed of the controller.

Integration Time (min): [1...240...255]

Defines the reset time of controller. Integration Time has the effect of moving the room temperature slowly toward, and ultimately reaching the setpoint value. Depending on the type of system used, parameter needs to have different values. In general, the more inactive the overall system, the greater time is needed.

Send Value on Change (%): [0...4...100] 0=inactive

Heating control value will be sent on change of percentage via Object “General Temperature (RTC)– Heating PI Control Value”.

Sending Interval (min): [0...15...255]

Determines cyclic sending period of Object “General Temperature (RTC) – Heating PI Control Value”.

Additional Stage: Explained in [#3.2.4.1.6. Heating - Additional Stage](#)

3.2.4.1.6. Heating - Additional Stage

Additional Stage: [Disable...Enable]

Additional Heating Control object can be enabled if an extra Heating Control Value is needed on top of main Heat Control Value.

Object "General Temperature (RTC) – Heating Additional Stage Value" is created when parameter is enabled.

Disable from Bus: Object "General Temperature (RTC) – Heating Additional Stage (0-Disable)" can be used to disable additional heating control any time by writing True/False.

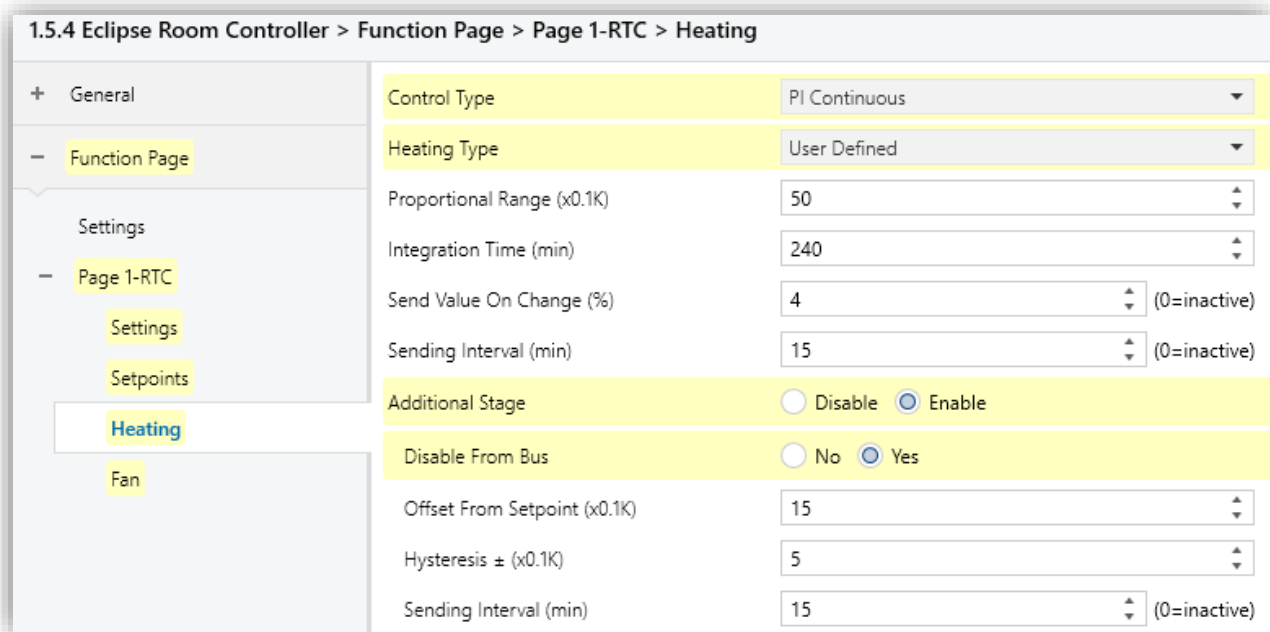

Offset from Setpoint (x 0.1 °C): [1...15...255]

Defines a separate setpoint value based on main Setpoint temperature for Object "General Temperature (RTC) – Heating Additional Stage Value". In this way, Additional Heating Source will be activated/deactivated depending on new temperature setpoint.

Example: Assume that a room has two type of different heating sources. (Main heating source, additional heating source)

Setpoint temperature is 24 degree for the "Heating Control Value" (main heating source.)

If "Offset from Setpoint" parameter is; $-20 \times 0.1 \text{ C}^\circ = -2 \text{ C}^\circ$.

In this scenario, the setpoint for heating is set to 24 °C. When the temperature falls below 22 °C, additional heating should be switched on so that the room heats up again rapidly.

Hysteresis +/- (x 0.1 °C): [1...5...255]

Determines Hysteresis value to control Heating Additional Stage Value more accurate. "Hysteresis" prevents the output value from oscillation and give larger margin to turning heat or cool ON and OFF. If system is more an active system, hysteresis values should be given larger and more inactive values.

Sending Interval (min): [0...15...255]

Determines cyclic sending period of Object "General Temperature (RTC) – Heating Additional Stage Value".

3.2.4.1.7. Cooling - Control Type: [2-Point Control ON/OFF]

Control Type: [2-Point Control (On/Off), Switching PI Control (PWM), Continuous PI Control]

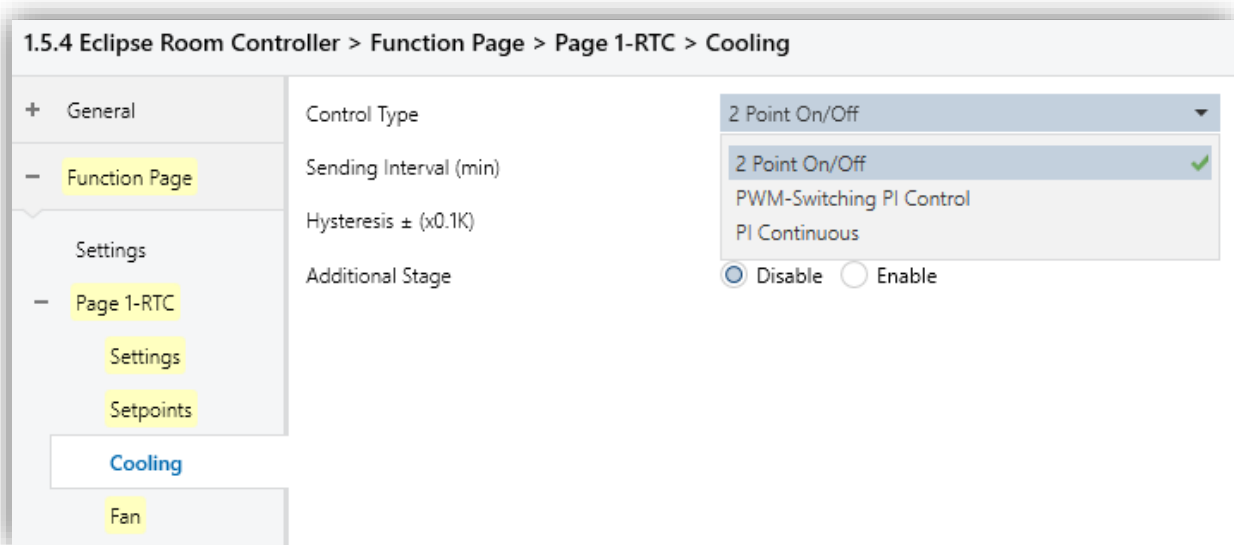

Operates as a simple switch around the setpoint temperature using hysteresis values. "Hysteresis" prevents the output value from oscillation and give larger margin to turning heat or cool on and off. If system is more an active system, hysteresis values should be given larger and more inactive values.

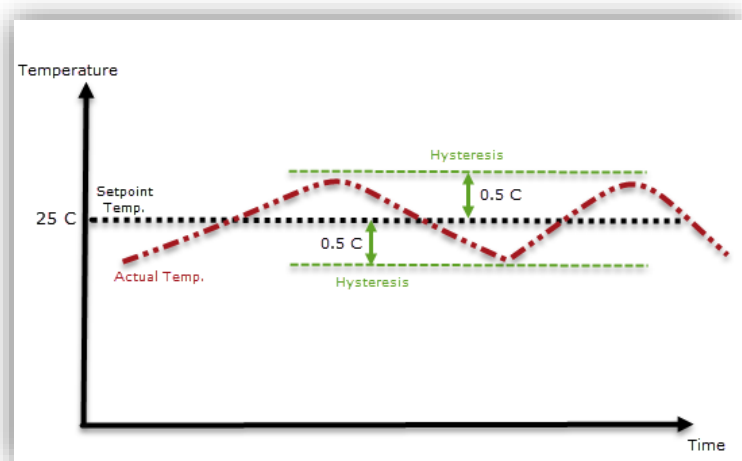

Sending Interval (min): [0...15...255] 0=inactive

Determines cyclic sending period of Object "General Thermostat - Cooling 2 Point Control Value".

Hysteresis +/- (x 0.1 °C): [1...5...255]

Determines Hysteresis value to control "Heating 2 Point Control Value" output more accurate. "Hysteresis" prevents the output value from oscillation and give larger margin to turning heat or cool ON and OFF. If system is more an active system, hysteresis values should be given larger and more inactive values.

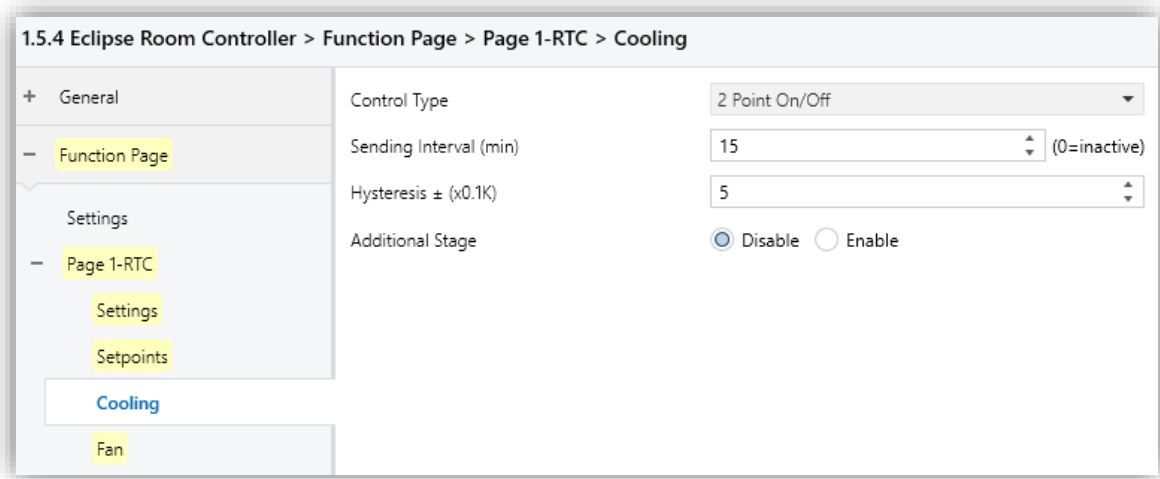

Additional Stage: Explained in #3.2.4.1.10. Cooling – Additional Stage

3.2.4.1.8. Cooling - Control Type: [Switching PI Control PWM]

PI algorithm is used to calculate control signal. After calculation, control signal is converted into a pulse-interval signal. This means PWM cycle is divided into "1 bit ON/OFF" output commands based on control value. PWM period and type of cooling should be selected according to the used room and type of cooling source.

PWM Period Time (min): [1...10...255]

Defines PWM period time. If control value is calculated %50. Then control value will be ON for 5 minutes and OFF for second 5 minutes. Please check following graphic.

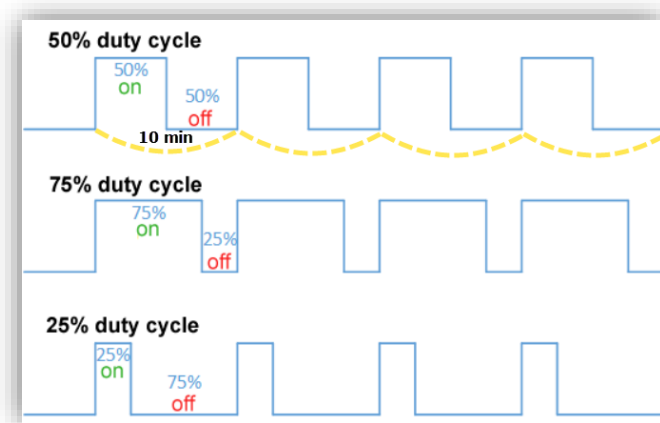

Type of Cooling: Multiple cooling types with preset parameters are available to the user.

- Cooling Ceiling (5K/240)
- Fan coil (4K/90)
- User Defined

If required cooling type is not available, individual parameters can be specified in the “User Defined” configuration.

Proportional Range (x0.1 °C): [10...50...100]

Defines the proportional range of control. Parameter changes the control speed of the controller.

Integration Time (min): [1...240...255]

Defines the reset time of controller. Integration Time has the effect of moving the room temperature slowly toward, and ultimately reaching the setpoint value. Depending on the type of system used, parameter needs to have different values. In general, the more inactive the overall system, the greater time is needed.

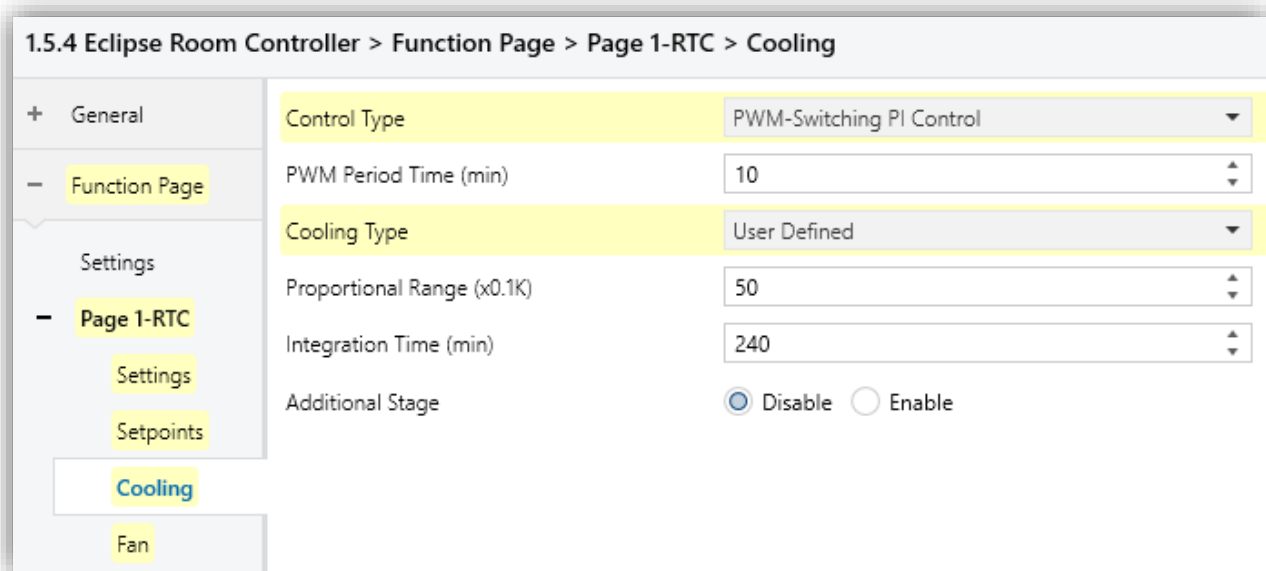

Additional Stage: Explained in [#3.2.4.1.10. Cooling – Additional Stage](#)

3.2.4.1.9. Cooling - Control Type: [Continuous PI Control PWM]

PI algorithm is used to calculate control signal and adjusts its output value between 0% and 100% to match the difference between the actual temperature and the setpoint temperature and enables an accurate regulation of the room temperature to the setpoint value. PI values should be selected compatible with the room and the type of heating system that needs to be controlled. Default PI values are defined for most common cooling types. User defined values can be used for different rooms and different cooling types for better performance. Using default values as a reference point and adjusting these values according to system might increase controller performance.

Cooling Type: Multiple cooling types with preset parameters are available to the user.

- Cooling Ceiling (5K/240)
- Fan coil (4K/90)
- User Defined

If the required cooling type is not available, individual parameters can be specified in the “User Defined” configuration.

Send Value On Change (%): [0...4...100] 0=inactive

Cooling control value will be sent on change of percentage via Object “General Temperature (RTC)–Cooling PI Control Value”.

Sending Interval (min): [0...15...255]

Determines cyclic sending period of Object “General Temperature (RTC) – Cooling PI Control Value”.

Additional Stage: Explained in [#3.2.4.1.10. Cooling – Additional Stage](#)

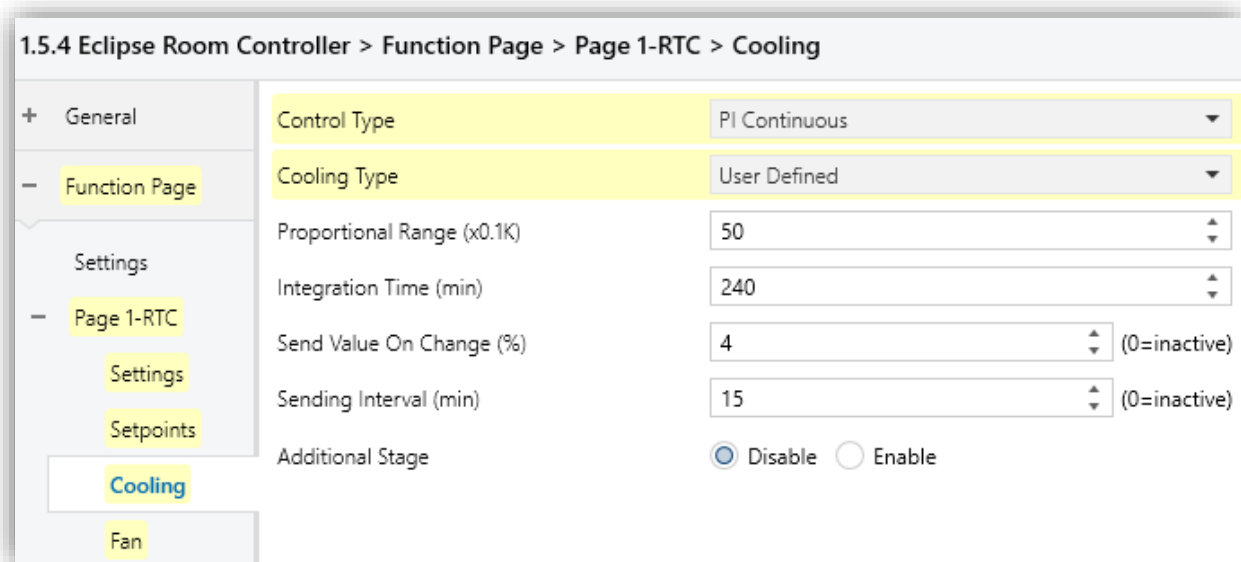

3.2.4.1.10. Cooling – Additional Stage

Additional Stage: [Disable...Enable]

Additional Cooling Control object can be enabled if an extra Cooling Control Value is needed on top of main Cooling Control Value.

Object “General Temperature (RTC) – Cooling Additional Stage Value” is created when parameter is enabled.

Disable from Bus: Object “General Temperature (RTC) – Cooling Additional Stage (0-Disable)” can be used to disable additional heating control any time by writing True/False.

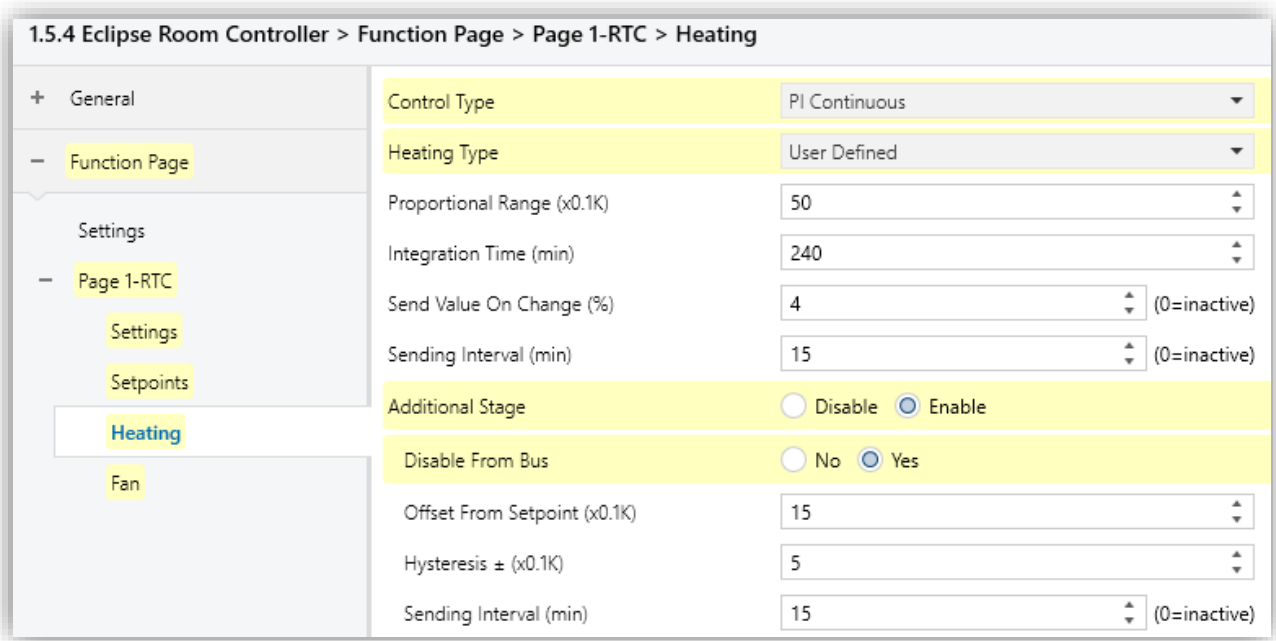

Offset from Setpoint (x 0.1 °C): [1...15...255]

Defines a separate setpoint value based on main Setpoint temperature for Object “General Temperature (RTC) – Cooling Additional Stage Value”. In this way, Additional Cooling Source will be activated/deactivated depending on new temperature setpoint.

Example: Assume that a room has two type of different heating sources. (Main cooling source, additional cooling source)

Setpoint temperature is 24 degree for the “Cooling Control Value” (main cooling source.)

If “Offset from Setpoint” parameter is; $-20 \times 0.1 \text{ C}^\circ = -2 \text{ }^\circ\text{C}$.

In this scenario, the setpoint for cooling is set to 24 °C. When the temperature rises above 26 °C, additional cooling should be switched on so that the room cools off again rapidly.

Hysteresis +/- (x 0.1 °C): [1...5...255]

Determines Hysteresis value to control Cooling Additional Stage Value more accurate. “Hysteresis” prevents the output value from oscillation and give larger margin to turning heat or cool ON and OFF. If system is more an active system, hysteresis values should be given larger and more inactive values.

Sending Interval (min): [0...15...255]

Determines cyclic sending period of Object “General Temperature (RTC) – Cooling Additional Stage Value”.

3.2.4.1.11. Heating & Cooling

Control mode of thermostat can be selected for Heating, Cooling, and Heating & Cooling.

If Heating & Cooling control mode is selected parameter tabs of "Heating" and "Cooling" will place with same parameters. However parameter tabs of "Thermostat Settings" and "Setpoint Temperature" will have some additional parameters.

Please check below.

-Thermostat Settings

Heating & Cooling Control Value Output: Output value for Heating and Cooling can be sent via same object or 2 separate objects.

If "via 1 Object" option is selected Object "General Thermostat (RTC) – Heating/Cooling Control Value" will be activated.

22	Page 1-General Thermostat (RTC)	Heating/Cooling PI Control Value	1 byte	percentage (0..100%)
----	---------------------------------	----------------------------------	--------	----------------------

If "via 2 Objects" option is selected Object "General Thermostat (RTC) – Heating Control Value" and Object "General Thermostat (RTC) – Cooling Control Value" will be activated.

20	Page 1-General Thermostat (RTC)	Heating PI Control Value	1 byte	percentage (0..100%)
21	Page 1-General Thermostat (RTC)	Cooling PI Control Value	1 byte	percentage (0..100%)

1.5.4 Eclipse Room Controller > Function Page > Page 1-RTC > Settings

General	Control Modes	Heating And Cooling
Function Page	Heating and Cooling Control Value Output	<input type="radio"/> via 1 Object <input checked="" type="radio"/> via 2 Objects
Settings	Behaviour of Control Mode at Bus Recovery	As before voltage failure
Page 1-RTC	Switchover Control Mode	Only via Object
Settings	Temperature Sensor	<input checked="" type="radio"/> Internal <input type="radio"/> External
Setpoints	Window Contact	<input type="radio"/> Disable <input checked="" type="radio"/> Enable
Heating	Window Contact Value	<input checked="" type="radio"/> Inverted <input type="radio"/> Not Inverted
Cooling	Thermostat On/Off Function	<input type="radio"/> Disable <input checked="" type="radio"/> Enable
Fan		

Behavior of Control Mode at Bus Recovery:

The parameter defines the behavior of the control mode after bus power return. Control mode can be changed to following options after a power return:

- As before voltage failure
- Heating
- Cooling

Switchover Control Mode: [Only via Object, Local and via Object, Automatic]

Parameter makes possible to switch between the heating and cooling mode of the general thermostat.

Only via Object:

Switchover can be applied only “via Object” manually using Object “General Thermostat (RTC)– Heat/Cool Switchover”.

\$01= Heating [1.100 DPT_cooling/heating]

\$00= Cooling [1.100 DPT_cooling/heating]

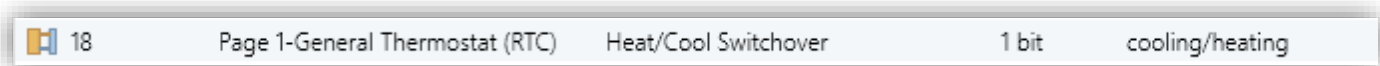

Local and via Object:

Switchover can be applied locally on Control Element Page and also “via Object” manually using Object “General Thermostat (RTC) – Heat/Cool Switchover”.

Automatic: The thermostat switches automatically between heating and cooling and to the associated setpoint according to defined “Deadband”. Object “Thermostat – Heat/Cool Status” will transmit the status after switchover.



“Automatic switchover” function performs only if current operation mode is “Comfort Mode”. Otherwise thermostat is not going to switchover heating and cooling!

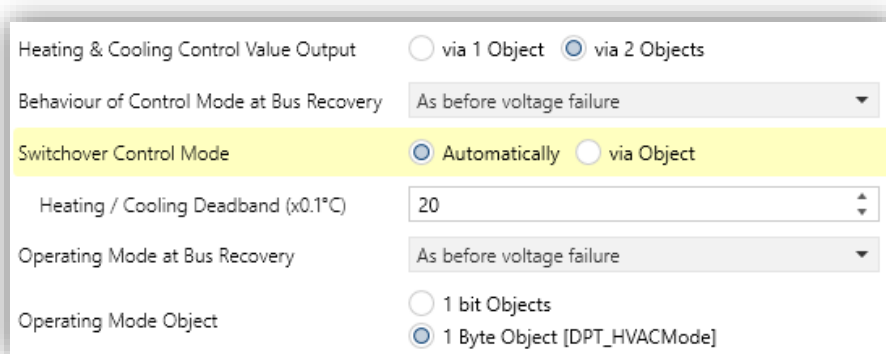



Heating Cooling Deadband (x 0.1 °C): [0...**20**...255]

Deadband defines the range between setpoint temperature and measured temperature. If deadband is exceeded, switchover will be applied.

-Heating/Cooling Object Description

Heating / Cooling Indication

Object “General Thermostat (RTC) – Heating Indication” defines a state for recent heating command. It indicates that heating source is recently having an active command to heat. In same way, Object “General Thermostat (RTC) – Cooling Indication” defines a state for recent cooling command. It indicates that cooling source is recently having an active command to cool.

	160	Thermostat	Heating Indication	1 bit	state
	161	Thermostat	Cooling Indication	1 bit	state

Example: Heating mode is active. Setpoint Temperature 22 °C, Actual Temperature 21 °C.

Heating control value is sending ON command to heating source and “heating indication” is instantly informing about heating command.

10:59:52.375	1.5.8	0/7/3	GroupValue_Write	Setpoint Indication	0C 4C 22 °C
10:59:52.398	1.5.8	0/7/6	GroupValue_Write	Actual Temperature	0C 6A 22.6 °C
11:00:26.114	1.5.8	0/7/4	GroupValue_Write	Heating Control Value	\$00 Off
11:00:52.635	1.5.8	0/7/3	GroupValue_Write	Setpoint Indication	0C 4C 22 °C
11:00:52.658	1.5.8	0/7/6	GroupValue_Write	Actual Temperature	0C 6A 22.6 °C
11:01:05.541	15.15.241	0/7/18	GroupValue_Write	External Value	0C 1A 21 °C
11:01:07.700	1.5.8	0/7/6	GroupValue_Write	Actual Temperature	0C 1A 21 °C
11:01:08.299	1.5.8	0/7/4	GroupValue_Write	Heating Control Value	\$01 On
11:01:08.320	1.5.8	0/7/23	GroupValue_Write	Heating Indication	\$01 Active

3.2.4.1.12. Fan

1.5.4 Eclipse Room Controller > Function Page > Page 1-RTC > Fan

+ General

- Function Page

Settings

- Page 1-RTC

Settings

Setpoints

Heating

Cooling

Fan

Fan Control Disable Enable

Fan Display Heating ▾

Control Unit has Fan Off No Yes

Fan Off Control Object Inverted Not Inverted

Control Unit has Fan Auto No Yes

Fan Auto/Manual Object Disable Enable

Fan Auto/Manual Control Value Inverted Not Inverted

Number of Fan Stages 4 ▾

Fan Stage Object Type 1 Bit 1 Byte

Enumerated Scaling

Fan Display: [Heating, Cooling, Heating and Cooling]

Fan can be visible only for selected control modes.

Control Unit has Fan Off:

Parameter can be activated if actuator has a “Fan OFF” object. “Fan OFF” command can be sent to the actuator via Object “General Thermostat (RTC) –Fan Off (1-Off)” will be visible.

50	Page 1-General Thermostat (RTC)	Fan Off (1-Off)	1 bit	state
51	Page 1-General Thermostat (RTC)	Status Fan Off (1-Off)	1 bit	state

Fan off Control Object:

Fan off command can be used inverse. [True or False]

Control Unit has Fan Auto:

Parameter can be activated if actuator has a “Fan auto” function.

Fan Auto/Manual Object:

“Fan auto” command can be sent to the actuator via Object “General Thermostat (RTC) –Fan Auto/Manual (1-Auto)” will be visible.

48	Page 1-General Thermostat (RTC)	Fan Auto/Manual (1-Auto)	1 bit	state
----	---------------------------------	--------------------------	-------	-------

Fan Auto/Manual Control Value:

Fan auto command can be used inverse. [True or False]

Number of Fan Stages: [1...3...5]

Number of Fan levels can be changed according to control unit. Object will be available according to selection.

36	Page 1-General Thermostat (RTC)	Fan Speed Enumerated (0,1,2,3,4)	1 byte	fan stage (0..255)
37	Page 1-General Thermostat (RTC)	Status Fan Speed Enumerated (0,1,2,3,4)	1 byte	fan stage (0..255)

Fan Stage Object Type: [1 bit, 1 Byte]

Type of Fan stage object can be changed as 1 bit or 1 Byte. 1 Byte object can be used as “Enumerated” or “Scaling”.

Fan Speed Enumerated (0, 1, 2, 3, 4)

Fan Speed Scaling (0, 25, 50, 75, 100) %

1 bit objects;

38	Page 1-General Thermostat (RTC)	Fan 1	1 bit	state
39	Page 1-General Thermostat (RTC)	Status Fan 1	1 bit	state
40	Page 1-General Thermostat (RTC)	Fan 2	1 bit	state
41	Page 1-General Thermostat (RTC)	Status Fan 2	1 bit	state
42	Page 1-General Thermostat (RTC)	Fan 3	1 bit	state
43	Page 1-General Thermostat (RTC)	Status Fan 3	1 bit	state
44	Page 1-General Thermostat (RTC)	Fan 4	1 bit	state
45	Page 1-General Thermostat (RTC)	Status Fan 4	1 bit	state

3.2.4.2. Slave Thermostat

“Slave Thermostat” function does not actively control the Hvac actuator. Instead, it is used to display and send commands to another “Thermostat” which is actively controlling the Hvac actuator. Basically, “Slave thermostat” function is a copy of main “Thermostat”.

Temperature Sensor:

Temperature value can be received from an external temperature sensor directly or internal sensor can be used as default.

Operating Mode 1 Bit Objects:

Parameter determines the data type of operating mode objects. Data type of operating mode objects can be used as “1 bit” with separate objects for each operating mode if this parameter is enabled. Status Objects will send current status of operating mode after change.

28	Page 1-General Thermostat (RTC)	Comfort Mode	1 bit	state	C - W - -
29	Page 1-General Thermostat (RTC)	Status Comfort Mode	1 bit	state	C R - T -
30	Page 1-General Thermostat (RTC)	Standby Mode	1 bit	state	C - W - -
31	Page 1-General Thermostat (RTC)	Status Standby Mode	1 bit	state	C R - T -
32	Page 1-General Thermostat (RTC)	Economy/Night Mode	1 bit	state	C - W - -
33	Page 1-General Thermostat (RTC)	Status Economy/Night Mode	1 bit	state	C R - T -
34	Page 1-General Thermostat (RTC)	Building Protection Mode	1 bit	state	C - W - -
35	Page 1-General Thermostat (RTC)	Status Building Protection Mode	1 bit	state	C R - T -

Fan Control: [Disable, Enable]

Check Fan section for description of fan parameters. [3.2.4.1.12. Fan](#)

Heat/Cool Switchover:

Parameter makes possible to switch between the heating and cooling mode of the main thermostat.

Thermostat ON/OFF Function:

Thermostat ON/OFF Function is used to turn the thermostat on/off. Switch object and status object will be created after this parameter is enabled.

3.2.4.3. Air Conditioner Control

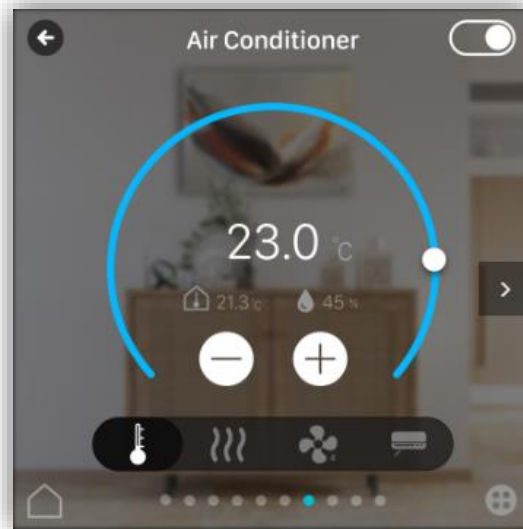

Figure 11 - Air Conditioner Control

“Function” contains special communication objects to control an air conditioner via a KNX gateway.

Control Mode Object Type: [1 bit, 1 Byte]

Control mode can be selected using Object “Control Modes (0-Auto, 1-Heat, 3-Cool, 9-Fan, 14-Dry)” Heating, Cooling, and Heating & Cooling.

25	Page 1-Air Conditioner	Status Control Modes (0-Auto,1-Heat, 3-Cool, 9-Fan, 14-Dry)	1 byte	HVAC control mode
----	------------------------	-------------------------------------------------------------	--------	-------------------

Heat/Cool Mode 1 Bit Object: [Disable, **Enable**]

Parameter enables the switchover object to change between heating and cooling mode.

Control Unit has Fan Auto:

Check Fan section for Fan parameters. [3.2.4.1.12. Fan](#)

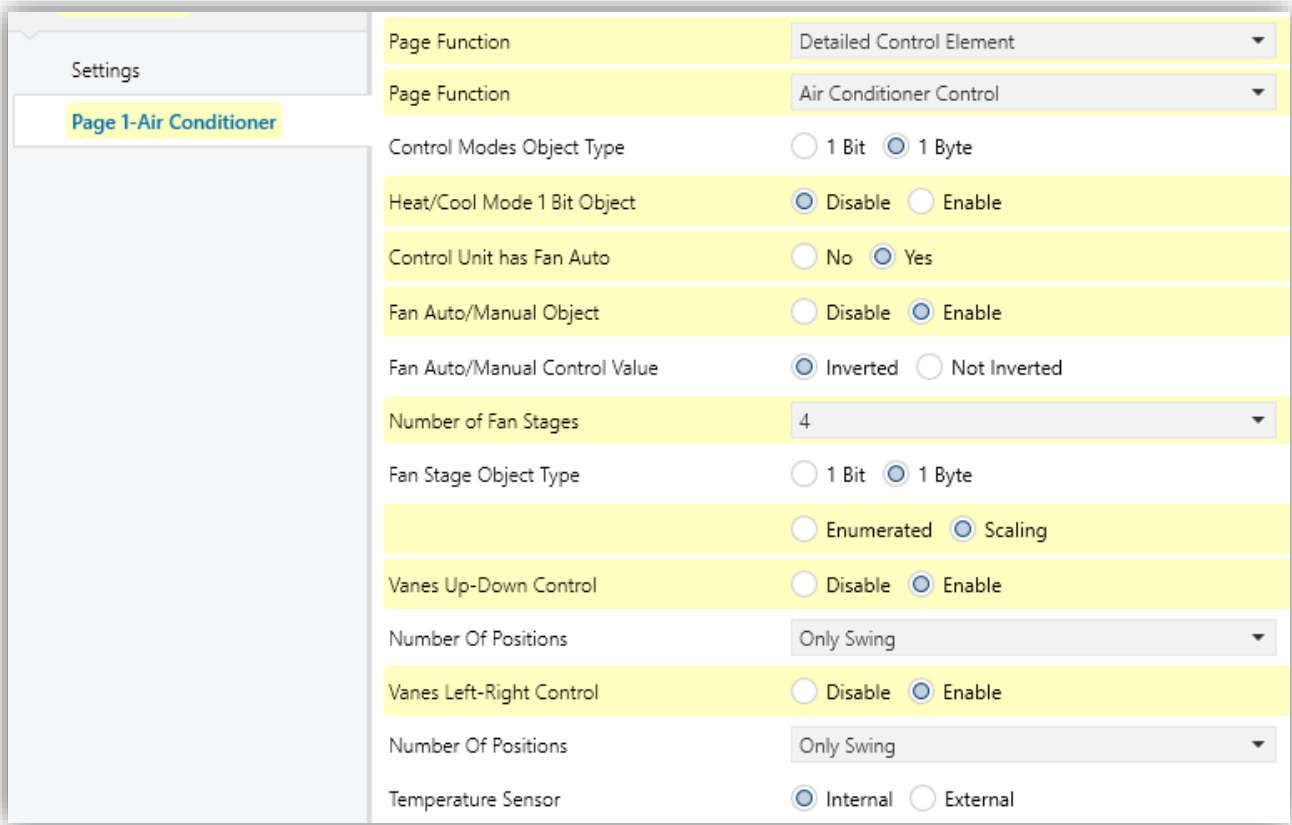

Vanes Up-Down Control:

Up-Down vane control can be activated using Object Vanes Up-Down (1-Swing, 0-Off)

52	Page 1-Air Conditioner	Vanes Up-Down Swing (1-Swing, 0-Off)	1 bit	boolean
53	Page 1-Air Conditioner	Status Vanes Up-Down Swing (1-Swing, 0-Off)	1 bit	boolean

Number of positions: [Only swing, 1...8]

Number of positions can be defined using parameter. Object type will change as 1 byte.

50	Page 1-Air Conditioner	Vanes Up-Down	1 byte	counter pulses (0..255)
51	Page 1-Air Conditioner	Status Vanes Up-Down	1 byte	counter pulses (0..255)

Vanes Left-Right Control:

Left-Right vane control can be activated using Object Vanes Left-Right (1-Swing, 0-Off)

56	Page 1-Air Conditioner	Vanes Left-Right Swing (1-Swing, 0-Off)	1 bit	boolean
57	Page 1-Air Conditioner	Status Vanes Left-Right Swing (1-Swing, 0-Off)	1 bit	boolean

Number of positions: [Only swing, 1...8]

Number of positions can be defined using parameter. Object type will change as 1 byte.

54	Page 1-Air Conditioner	Vanes Left-Right	1 byte	counter pulses (0..255)
55	Page 1-Air Conditioner	Status Vanes Left-Right	1 byte	counter pulses (0..255)

Temperature Sensor:

Temperature value can be received from an external temperature sensor directly or internal sensor can be used as default.

3.2.4.4 Audio Control

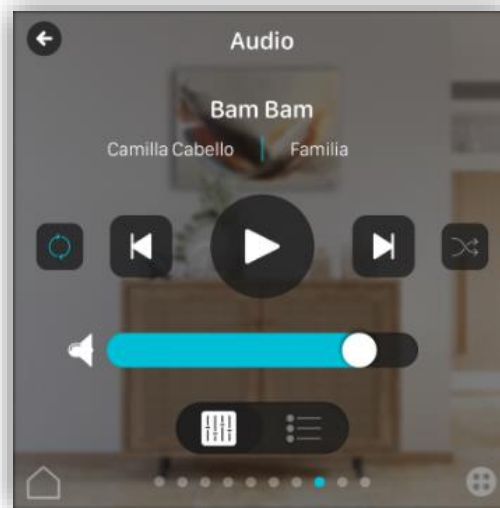

Figure 12 - Audio Control

Audio Control page allows to manage any KNX audio controller via following KNX objects.

13	Page 1-Audio	Play/Pause	1 bit	start/stop
14	Page 1-Audio	Status Play/Pause	1 bit	start/stop
15	Page 1-Audio	Volume	1 byte	percentage (0..100%)
16	Page 1-Audio	Status Volume	1 byte	percentage (0..100%)
17	Page 1-Audio	Mute/Unmute	1 bit	enable
18	Page 1-Audio	Status Mute/Unmute	1 bit	enable
19	Page 1-Audio	Next/Previous	1 bit	step
20	Page 1-Audio	Playlist Selection	1 byte	counter pulses (0..255)
21	Page 1-Audio	Current Playlist	1 byte	counter pulses (0..255)
22	Page 1-Audio	Shuffle/No Shuffle	1 bit	enable
23	Page 1-Audio	Status Shuffle/No Shuffle	1 bit	enable
24	Page 1-Audio	Repeat/No Repeat	1 bit	enable
25	Page 1-Audio	Status Repeat/No Repeat	1 bit	enable
26	Page 1-Audio	Song Name	14 bytes	Character String (ISO 8859-1)
27	Page 1-Audio	Artist Name	14 bytes	Character String (ISO 8859-1)
28	Page 1-Audio	Album Name	14 bytes	Character String (ISO 8859-1)
29	Page 1-Audio	Playlist Name	14 bytes	Character String (ISO 8859-1)

3.2.5. Page 1 – Status Display

“Status Display” can be used to show customized status information using selectable icons and data point types.

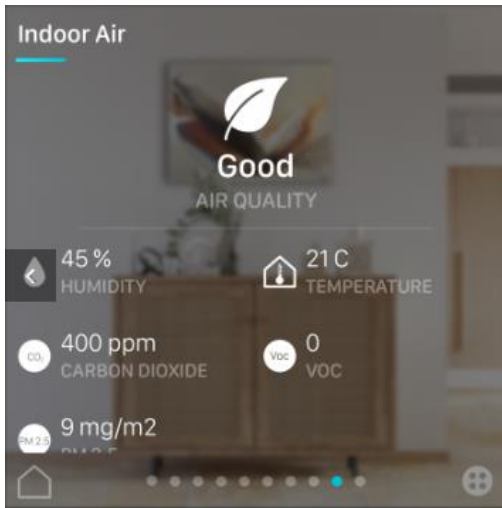

Figure 13 - Air Quality Display

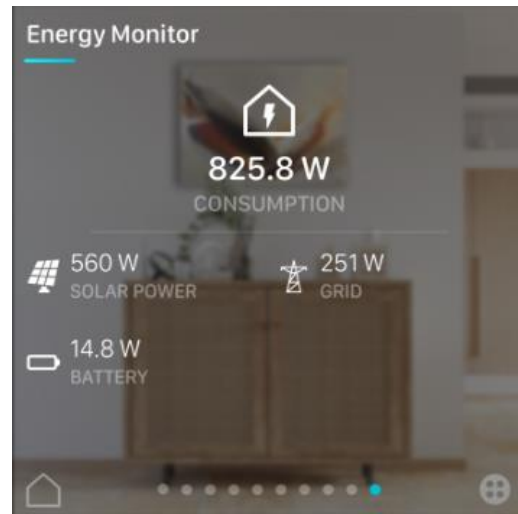

Figure 14 - Energy Monitor

Number of status element: [1...8]

A maximum of 8 status elements can be added to same page.

Icon:

Selected icon will be visible near status element. Figure 13, 14

Text: (16 characters allowed)

Description will be visible below the value and unit. Figure 13, 14

Data point type of status item 1: Following data types can be used;

- DPT 7 (2 Byte Unsigned)
- DPT 9 (2 Byte Float)
- DPT 13 (4 Byte Signed)
- DPT 14 (4 Byte Float)

Unit: (16 characters allowed)

“Unit” will be visible near the value.

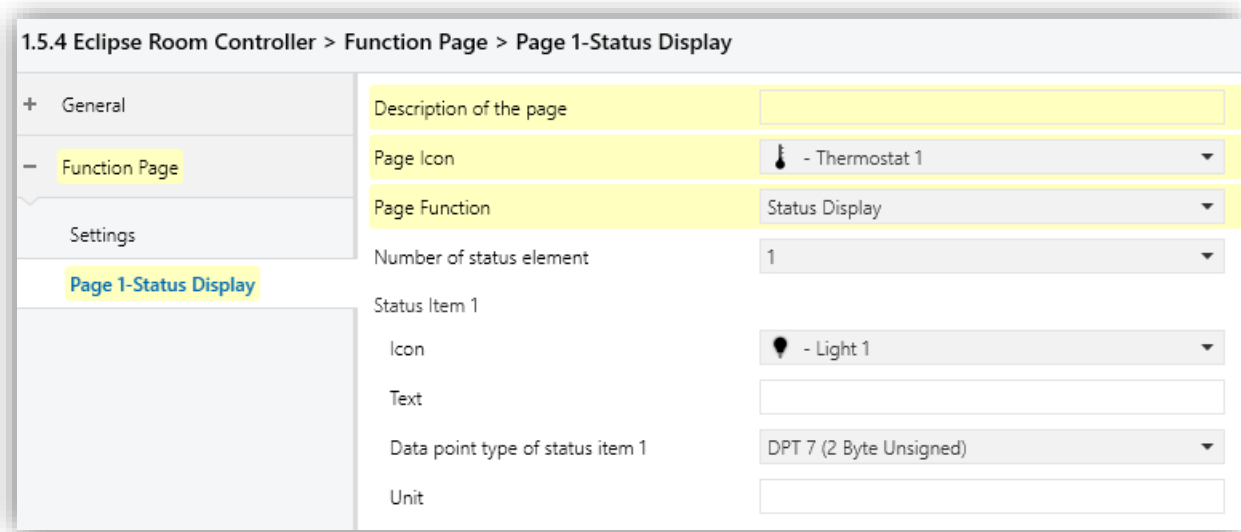

4. Commissioning

For commissioning the device, the following activities are required:

- Make electrical connections
- Turn on the bus power supply
- Switch the device operation to programming mode
 - Alternatively, instead of using programming button, it is possible to switch operation of the device to programming mode on settings menu by activating knx programming
- Download into device the physical address and the configuration with ETS program
- At the end of the download operation of the device returns to normal mode
- Now the device is programmed and ready to use



Configuration and commissioning of the device require the use of ETS4 or later releases. These activities must be carried out according to the design of the building automation system done by a qualified planner.